

GMT-X1

Weighing Transmitter

(Digital Version Available)



GMT-X1, a DIN rail-mounted weighing transmitter for industrial automation, can be used in various system weighing applications, such as weight checking, loss-in-weight, liquid filling, batching, vessel and silo weighing, etc. Through Bluetooth, it can be connected to Weasy App for configuration and monitoring.



SOFTWARE HIGHLIGHTS

- Liquid filling software selectable ;
- Calibration without weights (by loadcell sensitivity value) ;
- Printer function ;
- Self-testing for I/O and Communication port ;
- Self-editable boot screen ;



HARDWARE HIGHLIGHTS

- Stainless steel case with compact design ;
 - Different configuration choice, a variety of combinations ;
 - Standard: RS485 + RS485/RS232(Selectable)
 - Option 1** 3 Input 5 Output or 3 Input 4 Output relay (Optional) ;
 - Option 2** RS485+16bit Analog or 2 Input 4 Output or CAN OPEN ;
 - Option 3** Modbus TCP or Ethernet/IP or Profinet or Profibus DP ;
- (Hardware Option 1,2,3 can be selected at the same time) ;
- Bluetooth Communication.

Digital Version

Standard:

- RS232 or RS485 selectable;
- RS485 for digital loadcell interface;

Options:

Same as common version;



Standard Specification

	Model	GMT-X1	GMT-X1 Digital Version	
General Specifications	Power Supply	DC 24V(12~30VDC)		
	Working temperature	-10°C~40°C		
	Maximum humidity	90% RH.without dew		
	Testing standards	Class III 6000 e, 1μV/e		
	Power consumption	About 5W		
	Measurement Parameters	A/D performance	24 bit Delta-Sigma	N/A
A/D conversion speed		50~960 times/sec	N/A	
Non-linearity		0.01%F.S	N/A	
Gain drift		10PPM/°C	N/A	
Input sensitivity		0.1μV/d	N/A	
Display Accuracy		1/1,000,000	1/1,000,000	
Weighing Platform Requirement		1 simulation scale interface can connect up to 8 load cells with 350Ω, Support sensitivity in 1mV/V, 2mV/V, 3mV/V	1 standard RS485 digital loadcell interface	
Sensor power supply		DC 5V 200mA(Max)	DC12V 250mA, up to connect with 8 digital load cells	

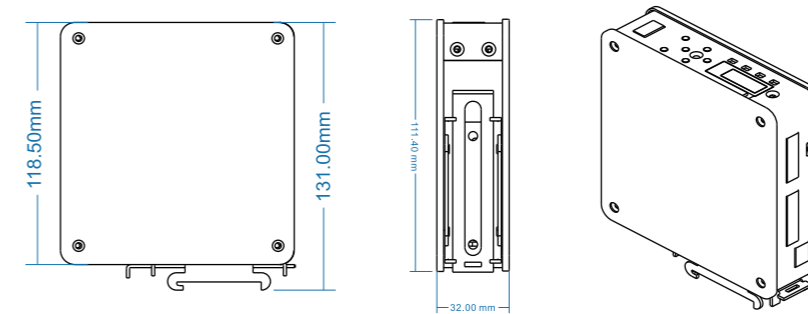

Application

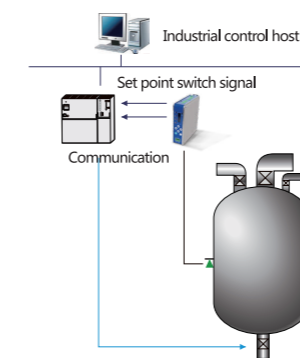

Set point weighing application

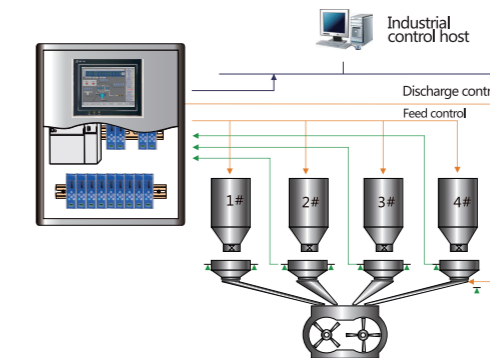

Multi-material batching application