

DUPLEX PACKING FILLER AF-10KII

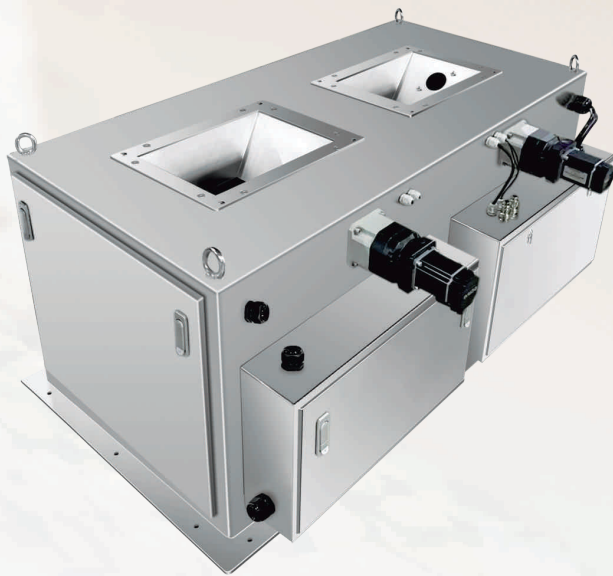

0.5-10kg
Weighing range



Stable
Performance



Easy
Installation

± 3g
Best accuracy



Servo Motor
Control



Weighing
Accurate

≥ 1600 + Pcs/h
Speed

Features:

- **Granular material:** design for rice, millet, beans and other granular material;
- **Easy dismounting:** module design of measuring hopper for easy cleaning;
- **Parameter setting:** self-adjust function with target value set only;
- **Stable performance:** servo motor controls feeding process;
- **Weighing accurate:** weighing range is 0.5-10kg. Speed can reach 2600 pcs/h when the fast algorithm is opened, and best accuracy $\pm 3g$.

Optional:



10-inch touch screen

User-friendly interface design,
vivid display, easy to operate.

Specification

Model	PaxGO AF-10K II
Weighing range	0.5~10Kg
Division	1g
Best Accuracy*	±3g
Speed*	≥1600 pcs/h(Enable fast algorithm:2600 pcs/h)
Volume	15L x 2
Feeding method	Servo motor + feeding vibrator , pneumatic discharging
Material	SS304,carbon steel
I/O	8 output(5V),8 input(24V)
Communication	RS485, Modbus TCP/IP
Pneumatic	0.4~0.6MPa
Power	Single Phase AC-220V ±10%,50/60HZ,500KW
Working environment	0~40°C , 90%R.H condensation is not allowed

*Normally, the diameter of the testing material 1-5mm.

Structure & Dimension

Unit: mm

