



杰 · 曼 · 科 · 技

# GM9907L2

## User's Manual

110608040006

V01.01.10

© 2020 Shenzhen General Measure Technology Co., Ltd. All rights reserved.

No unit or individual may copy, distribute, transcribe or translate into other language versions in any form or by any means without the permission of Shenzhen General Measure Technology Co., Ltd.

As our products have been continuously improved and updated, our company reserves the right to modify this manual at any time without prior notice. To do this, please visit the company website frequently to get timely information.

Company website <http://www.gmweighing.com>

Implementation standards of this product: **GB/T 7724—2008**



# Content

1.	Outline .....	- 1 -
1.1	Functions and Features.....	- 1 -
1.2	Front panel description.....	- 2 -
1.3	Rear panel description.....	- 3 -
1.4	Technical Specifications.....	- 3 -
2.	Installation .....	- 4 -
2.1	General principles .....	- 4 -
2.2	Load Cell connection .....	- 4 -
2.3	I/O Module Port connection.....	- 4 -
2.4	Power supply connection .....	- 5 -
2.5	Serial port connection .....	- 5 -
2.6	Network port connection.....	- 6 -
2.7	Touch screen calibration.....	- 6 -
3.	User Permission Description.....	- 7 -
4.	Menu.....	- 8 -
4.1	Calibration.....	- 9 -
4.2	Recipe parameters .....	- 10 -
4.2.1	Scale body structure parameters.....	- 14 -
4.3	Weight parameter .....	- 19 -
4.4	System Maintenance .....	- 20 -
4.4.1	Scale structure.....	- 20 -
4.4.2	Communication Setting.....	- 25 -
4.4.3	User Logic Program.....	- 26 -
4.4.4	Peripherals Select parameters .....	- 29 -
4.4.5	Reset .....	- 31 -
4.4.6	Hardware Test .....	- 31 -
4.4.7	Display Style.....	- 31 -
4.4.8	Tractor Parameters .....	- 32 -
4.5	Peripheral parameters.....	- 34 -
4.5.1	Patting Bag Parameters .....	- 34 -
4.5.2	Sewing Parameters.....	- 35 -
4.5.3	DISC Shaking Parameters.....	- 36 -
4.5.4	Conveyor Parameters .....	- 36 -
4.5.5	Coding Parameters .....	- 37 -
4.5.6	Aux. Pulse Ctrl Parameters .....	- 37 -
4.5.7	Fill& DISC OverTime Parameters .....	- 38 -
4.6	Motor parameter.....	- 38 -
4.6.1	Filler.....	- 38 -
4.6.2	Clamper.....	- 40 -
4.6.3	DISC(Parameters can be set in net weigher mode) .....	- 41 -
4.7	Statistics .....	- 43 -
4.8	I/O Function .....	- 44 -
4.8.1	<b>Output, input port definition .....</b>	<b>- 46 -</b>
4.9	COM Master Mode .....	- 54 -
5.	Function .....	- 56 -
5.1	Setting the working mode .....	- 56 -
5.2	Batches.....	- 56 -
5.3	Level control.....	- 56 -
5.3.1	Dual Supplement.....	- 56 -
5.3.2	Single Supplement .....	- 56 -
5.4	Quick setup .....	- 56 -
5.5	Adaptive function.....	- 57 -
5.6	U disk upgrade software.....	- 57 -
5.6.1	Foreground update process .....	- 57 -

5.6.2 Background update process .....	- 57 -
5.7 U disk upgrade boot interface .....	- 57 -
5.8 Decoupling function.....	- 58 -
5.9 Holder Movement Type .....	- 58 -
5.10 Use method of 3 - class conveyor for jumbo bag scale .....	- 59 -
5.11 Operation process of various mechanisms in the tractor system .....	- 59 -
6. Serial communication.....	- 61 -
6.1 Printing method.....	- 61 -
6.1.1 Auto print.....	- 61 -
6.1.2 Total cumulative printing .....	- 61 -
6.1.3 Recipe cumulative printing .....	- 62 -
6.1.4 User cumulative printing.....	- 62 -
6.2 Continuons mode data frame format.....	- 63 -
6.3 Re-Cont protocol.....	- 63 -
6.4 Modbus-RTU Protocol.....	- 63 -
6.4.1 Function code and abnormal code.....	- 63 -
6.4.2 MODBUS transmission mode .....	- 64 -
6.3.3 MODBUS address allocation .....	- 64 -
7. Automatic bagging process .....	- 89 -
7.1 Net Weigher Scale.....	- 89 -
7.2 Gross Weigher Scale .....	- 91 -
7.3 Jumbo bag scale .....	- 93 -
7.4 Valve port scale .....	- 94 -
7.5 PLC mode .....	- 95 -
7.6 Double scale interlocking bagging mode .....	- 95 -
7.7 Binyes Multi-scale mode.....	- 96 -
8. Motor working process.....	- 98 -
8.1 Motor filling section.....	- 98 -
8.1.1 Stepper motor filling.....	- 98 -
8.1.2 Ordinary motor filling.....	- 98 -
8.2 Motor clamper bag part.....	- 99 -
8.2.1 Step motor clamper bag .....	- 99 -
8.2.2 MotorDrive Dual-Limit clamper bag .....	- 99 -
8.3 Motor discharge part .....	- 100 -
8.3.1 Stepper motor discharge.....	- 100 -
8.3.2 MotorDrive single-limit discharge .....	- 101 -
8.3.3 MotorDrive dual-limit discharge.....	- 101 -
8.3.4 Normal motor rotaing discharge .....	- 102 -
8.3.5 Motor debug function .....	- 102 -
8.4 Tractor working process .....	- 103 -
9. Peripheral working process .....	- 104 -
9.1 Patting bag .....	- 104 -
9.2 Coding.....	- 104 -
9.3 Conveyor.....	- 105 -
9.4 Printing.....	- 105 -
9.5 Sewing machine .....	- 105 -
9.6 Discharge Shaking .....	- 106 -
9.7 Fill&DISC Overtime Parameter.....	- 106 -
9.8 Auxiliary Pulse.....	- 106 -
10. Dimension (mm) .....	- 108 -

# 1. Outline

**GM9907-L2** bagging controller is a new weighing control controller specially developed for the single scale incremental method automatic quantitative packing scale. The controller English displays interface for easy operation; completely new algorithm coarser and more accurate control so that the load; the USB port and dual port serial device to make it easier to system interconnect. It can be widely used in fill, chemical, grain and other industries that require quantitative packaging equipment.

## 1.1 Functions and Features

- Full English display interface, make the operation more intuitive and easy
- There are five modes of bagging application, net weigher, gross weigher, jumbo bag scale, valve scale, PLC.
- **28**-digital input and output control (12 in / **16** out), input and output port positions can be customized.
- I/O Module test function, convenient for debugging of packing scale
- Fully automatic double material speed, three material speed filling control, with jog filling function
- Twenty formulas can be stored to facilitate bagging of different range materials
- USB interface facilitates import and export of various parameters
- Fill control function, convenient control connection between bagging scale and front filling equipment
- Fill speed adaptive function
- IO User Logic programming
- Auto free fall correction function
- Multiple digital filtering
- Batch setting function
- Bag patting function, suitable for bagging of powder materials
- Automatic zero tracking
- Time / date function
- Three-level user identity setting
- Dual serial port, external serial printer, computer or second display
- With single port communication function, it is convenient to communicate with the host computer

## 1.2 Front panel description

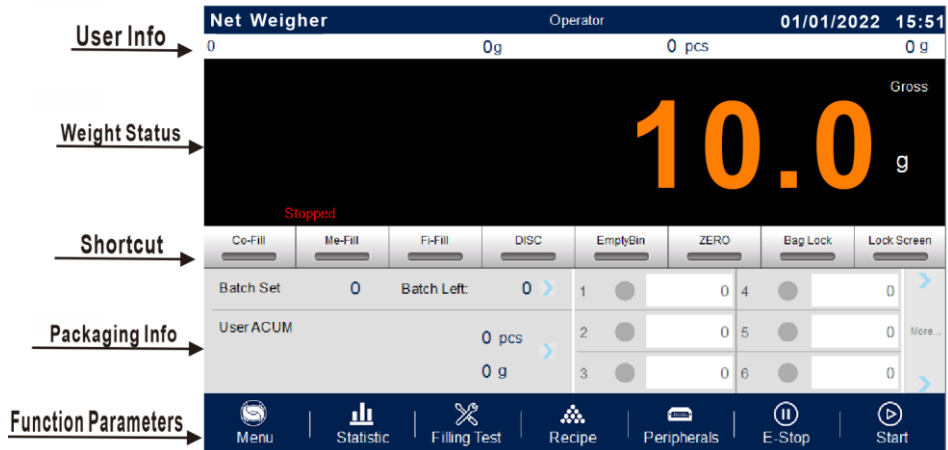

①User Info: Display the current login user ID, Recipe ID, System time, Total ACUM And Batch

②Weight status: Including weight value display, weight unit display, 8bit zone display and output I/O Module short cut key.

③Packaging information area: display current ACUM information, short cut setting batch and target value.

④Functional parameter area: Controller menu parameters query Settings and the corresponding operation keys

### Interface 1 description:

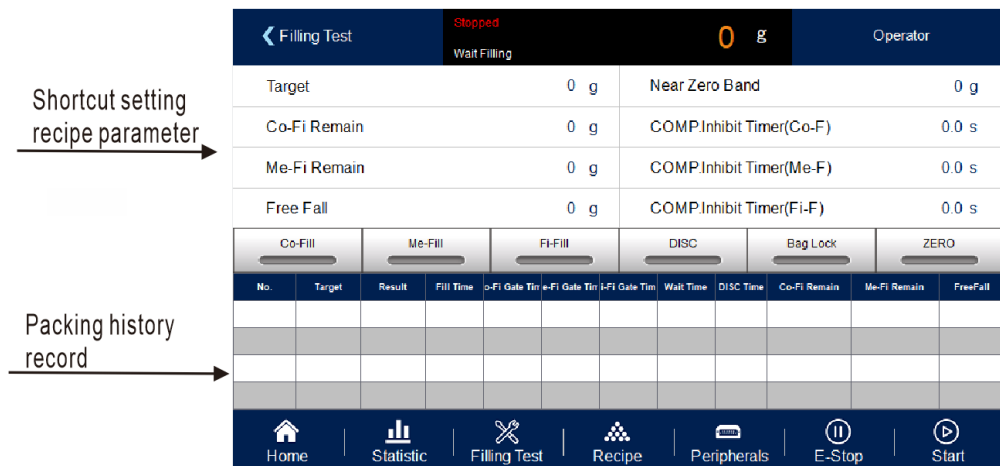

①Short cut set receipt pare:can quickly set receipt parameter.

②Packing history record:can easily review current history data, easy to compare.

### Indicator light description :

Right 1: power light;

### 1.3 Rear panel description

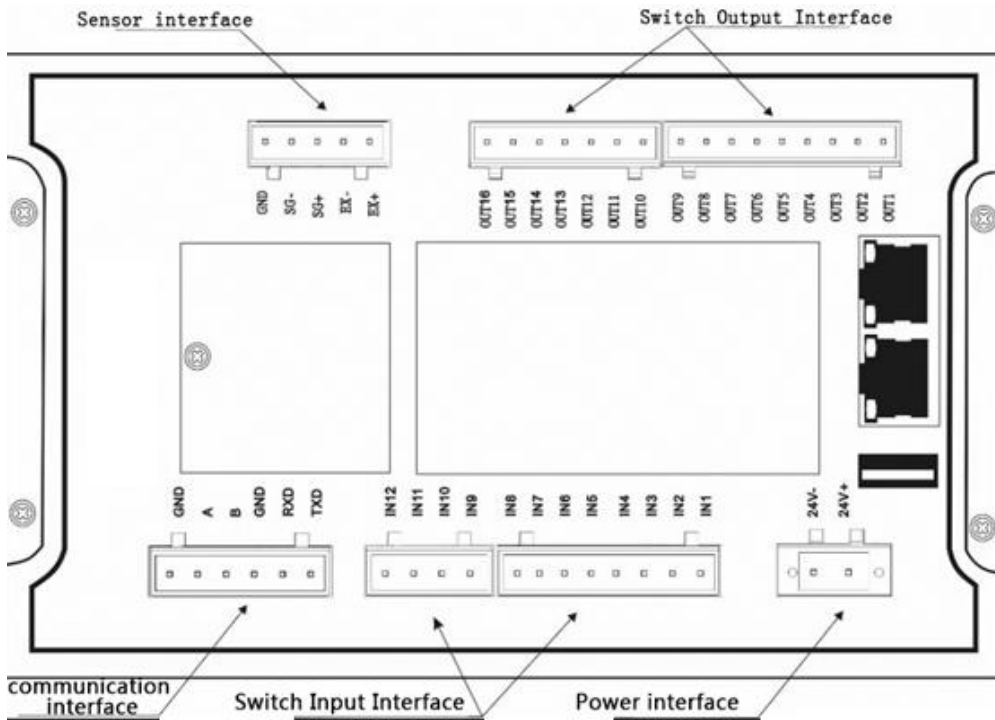

### 1.4 Technical Specifications

General specifications		Digital part	
Power supply	24V	Display	7 inch resistance touch screen
Power filter	Included	Negative display	“—”
Operating temperature	-10~40°C	Overload Indication	weight over range/low signal of load cell
Maximum humidity	90% RH without dew		
Power consumption	15W	Decimal point position	5 options
Dimensions	199mm × 133mm × 46.7mm		
Analog part			
Load cell power supply	DC5V 125mA (MAX)	Input impedance	10MΩ
Zero adjustment range	0.002~15mV (when load cell is 3mV/V)	Input sensitivity	0.02uV/d
Input range	0.02~15mV	Conversion	Sigma- Delta
A/D Conversion rate	120、240、480、960 Times/second	Non-linear	<b>0.01% F.S</b>
Gain drift	10PPM/°C	The maximum display accuracy	1/100000

## 2. Installation

### 2.1 General principles

- 1) Make appropriate installation holes on the control box, ( size: 181mm ×115mm)
  - 2) Install GM9907-L2 into a control box.
  - 3) Remove the fixing plates on both sides of GM9907-L2, fix it with the fixing plates and lock them with M3\*10 screws.
- ※Suggested torque for side strip screws: 3-5Kg.

### 2.2 Load Cell connection

**GM9907-L2** bagging controller can be connected to a resistive strain bridge load cell. When using a six-wire load cells, you must bridge the SN+ with EX+ and bridge the SN- with EX-.

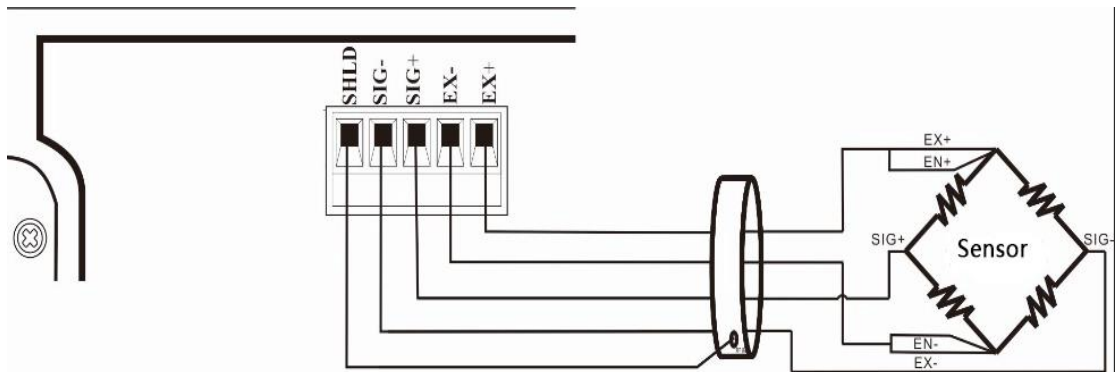

EX+:Excitation+ EX- : Excitation- SN+ : Sense+ SN- : Sense- SIG+ : Signal+ SIG- : Signal-

### 2.3 I/O Module Port connection

**GM9907-L2** bagging controller controls 28 lines I/O (12 input and 16 output). It uses optoelectronic isolation technology to transfer data. The I/O signal input is low level effective, and the output is open-collector mode. The driving current can reach 500mA and the full load current is up to 3A, and Terminal connection is shown as below:

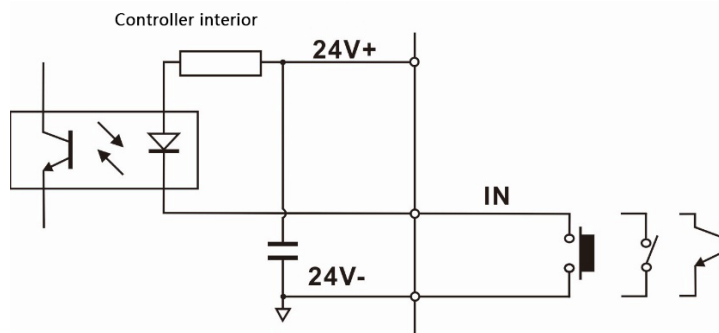

I/O Module Input port diagram



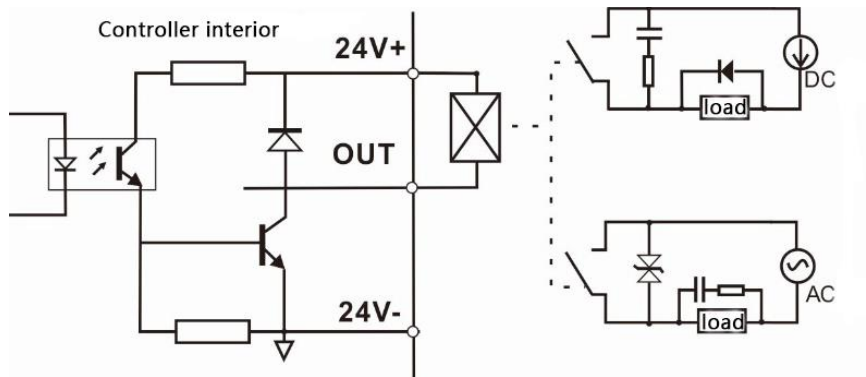

I/O Module output port diagram

I/O module value of **GM9907** is user-defined to facilitate wiring and some special applications. Please refer to section 4.8 for I/O function.

## 2.4 Power supply connection

**GM9907-L2** bagging controller use 24V DC power supply. The connection is as shown below:

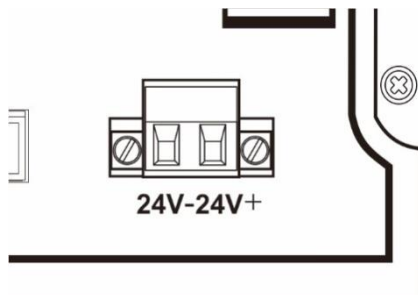

Power terminal diagram

**24V+ connect DC+, 24V- connect DC-.**

Note: this product use 24V DC power supply, use 220V AC power supply will permanently damage the controller and cause danger

## 2.5 Serial port connection

**GM9907-L2** provides two serial ports as shown in the figure below. One is **RS-232** mode (terminal port **TXD**, **RXD**, **GND**); the other is **RS-485**, (terminal port **A**, **B**, **GND**). Serial port support: modbus protocol, continuous mode, print, Re-Cont and Modbus\_8802S-p protocol.

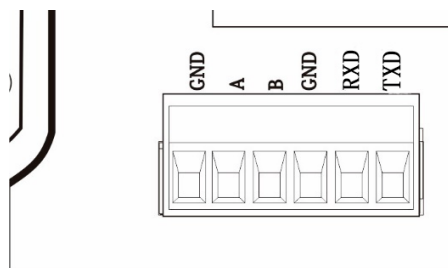

Controller and computer connection diagram

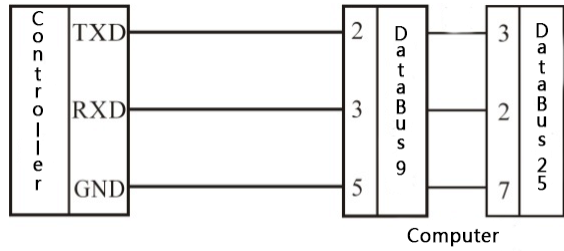

Controller and computer connection diagram (RS-232 mode)

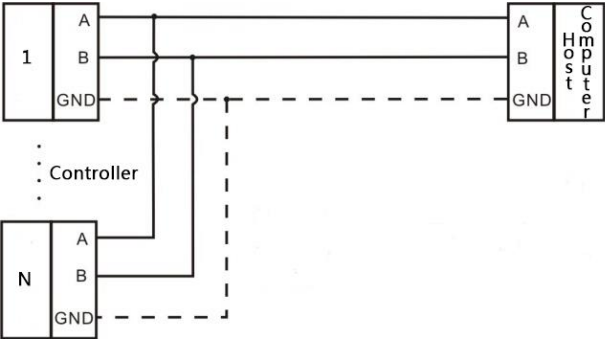

Controller and host computer connection diagram (RS-485 mode)

**2.6 Network port connection**

GM9907 provides two RJ45 interfaces and supports Modbus TCP communication. Under dual network ports, the network port is equipped with a built-in switch for easy cascading of instruments. The network port parameters can be set through the "Maintenance" - "Communication" parameter, and the corresponding Modbus communication address can refer to the Modbus address allocation in the [chapter 6.3.3 modbus address assignment](#) for details.

**2.7 Touch screen calibration**

The touch screen needs to be calibrated during the first use or after prolonged storage of the new product. Touch screen calibration method:

Power on GM9907 and long press any point on the touch screen. You can enter the touch screen calibration interface through the touch button set by the system parameters or by holding down the blank space for 3 seconds. The interface displays a cross cursor. Place your finger accurately at the center point of the cross cursor and hold it for at least 1 second to automatically enter the next calibration point. Long press and hold the center point of the crosshair in sequence, following the changes in its position, until all five points have been calibrated. Click on "Confirm calibration" to return to the system settings interface, and then click on "Enter Operating Environment" to enter the startup login interface.

### 3. User Permission Description

In order to prevent the malfunction of the controller caused by the malfunction of the controller, the **GM9907** bagging controller provides **three** levels of authority (operator, Technician and administrator) to choose: where the **administrator can perform all operations on the controller** (not open to the user) . Operator and Technician permissions are as follows:

User level	Permission
Operator	Can refer all parameters
	You can set part of the quantitative parameters and process parameters of the formula parameters, switch test, U disk data export.
	You can set batch on the main interface, clear the current formula accumulation, the current user accumulation, and operate the shortcut keys on the main interface.
Technician	All operations are not restricted.
	Can calibrate the scale, set the weighing parameters, set the formula parameters in the scale structure parameters and adaptive, over and under difference, drop correction and fine moving function parameters, I/O Module definition, set the language and time, modify the host mode parameters.
	Opened peripheral parameters can be modified.

Permission description:

- ◆ Controller default operator ID Login.
- ◆ Swift permission, click the parameter item that needs permission, and enter the password of the corresponding technician (**Password:0000**) or administrator (**Password:000000**) in the pop-up box to log in successfully.
- ◆ Click the parameter item that needs permission, and the current user's password can be modified in the pop-up box
- ◆ In the **【Display Style】** parameter of **【Maintenance】** , set the permission exit time, which is used to limit the login duration of technicians and system administrators. When the permission exit time reaches, the privileges of the current technicians or system administrator will be returned to the operator privileges
- ◆ Multi-user login function description: In the **【 Display Style 】** parameter of **【Maintenance】** , the multi-user login function is enabled, set the number of users to log in, and select users to log in when power on.

## 4. Menu

Press menu,can refer and modify parameters.

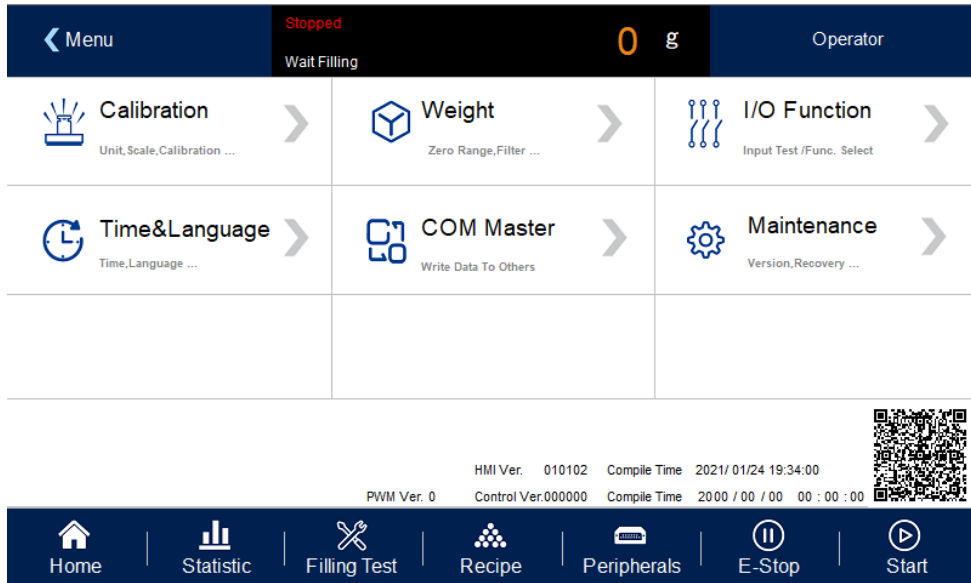

- ◆ Click each parameter item to view and set the home parameter information under the current parameter item.
- ◆ Click top left of interface to exit the current interface and return to the previous page.

Parameter	Parameter list	Description
Calibration	Weight Calibration	Use weight to calibrate
	Material calibration	Use material to calibrate
Weight	Zero range/filter lever setting	Set weight para, such as Zero range, stable para.
Recipe	Viewing recipe, setting filling values parameters	Set the filling values, process parameter and corresponding structural parameters of the scale body.
I/O Module	Input Define	Define the meaning of the controller input port
	Output Define	Define the meaning of the controller output port
	IO Test	Quickly access the hardware testing interface, can test whether the input and output ports are connected properly.
Time and Language	Language Setting	Default Chinese, English optional.
	Time Setting	Set screen time.
Host computer mode	Computer communication	Set computer mode parameter.
	Fill Gate Driver	Fill Gate Driver parameters setting

Motor(Scale Structure setting motor mode)	Clamper mode	Clamper motor parameter setting
	DISC Parameter	DISC motor Parameter setting
Maintenance	Scale Structure	Set scale structure, working mode,etc
	Communication	Set serial port, Ethernet.print etc.
	User Logic Program	Auxiliary logic parameter:6 group output logic parameter
	Peripheral Select	Set Peripherals parameter ON/OFF
	Reset	Set parameters factory default and backup.
	Hardware Test	Test input and output connection.
	Display Style	Set screensaver timer
	Firmware upgrade	Software upgrade
	System Info.	Check calibration times and check code
Tractor	If the peripherals switch selects the built-in tractor, this parameter is visible and tractor related parameters can be set.	

#### 4.1 Calibration

The calibration scale is the calibration of the controller. When the **GM9907** bagging controller or any part of the weighing system is changed for the first time and the current equipment calibration cannot meet the user's requirements, the controller should be calibrated. The calibration scale directly affects the weighing result of the controller. To prevent personnel from mis operation, the Technician and the administrator are required to log in to calibrate the controller (select the identity login in the [User Login] option).

The calibration scale of the national standard symmetrical heavy controller requires password protection. Therefore, the password must be entered correctly when entering the calibration interface (initial password: **000000**); the calibration password is changed in the "Password Management" item of [System Information]. .

In calibration interface, support two method: weight cal and material cal. Steps as follow:

Calibration parameter	Item parameter	Description
Weighing parameter	1. Weight unit	Initial value: <b>kg</b> ; <b>g/kg/t/lb</b> is available.
	2. Decimal point	Initial value: <b>0.00</b> ; <b>0</b> to <b>0.0000</b> five kinds of options.
	3. Division	Initial value: <b>1</b> ; <b>1/2/5/10/20/50</b> six optional .
	4. Full Scale	Initial value: <b>100.00</b> ; The range is less than or equal to the minimum division × <b>10 0000</b> can be set .
Weight Calibration	<p>The function of weight calibration is to use the weight calibration method in the field.Here are the steps:</p> <p><b>Step 1:</b> Select weighing parameters such as unit, decimal point and indexing value according to the demand.</p> <p><b>Step 2:</b> Empty the bucket and click [<b>Calibration Zero</b>].This step is the zero point of calibration, the requirements are: the measuring bucket</p>	

	<p>is empty, the scale body is stable.</p> <p><b>Step 3:</b> Put weights on the weighing table. When the weighing table is stable, click [<b>Calibration Weight</b>], input the weight of weights in the bullet frame, and click OK to complete the calibration of weights.</p>
Material calibration(Only for net weigher mode)	<p>Material calibration function is in the field is not convenient to use the weight of the calibration method.Here are the steps:</p> <p><b>Step1:</b> Empty the scale platform, wait for the millivolt to stabilize, and click "Calibration Zero ".This step is the zero point of calibration, the requirements are: the measuring bucket is empty, the scale body is stable.</p> <p><b>Step2:</b> Click "FILL", then the filling door will open, add material to the controlling bucket, click " FILL " again to close the filling door.(If the manual filling timer (Step2 time setting is manual filling time) is not set to 0, wait for the manual filling time to arrive, then automatically close the filling door)</p> <p><b>Step3:</b> Click [<b>Record Weight</b>]. At this point, the number on the right represents the millivolt value of the gain displayed after adding the material.</p> <p><b>Step4:</b> Click [<b>Manual DISC</b>]. At this point, the discharge door opens and the background will record the current relative millivolt count. Weigh the unloaded materials with an electronic scale and record the data.</p> <p><b>Step5:</b>Click [<b>Calibrate</b>] to input the weighing data and click OK.Material calibration is finished.</p>

## 4.2 Recipe parameters

Press recipe in Menu, enter 20 recipes choose interface, display recipe ID, name and target value.

- ◆ Click recipe ID, can swift recipe ID.
- ◆ Click on each recipe bar to enter the corresponding recipe parameter interface.
- ◆ Click upper left to return to the upper level interface.

Recipe parameter	parameter	Description
Filling Values	Used to set the bagging weight value related parameters	
	1. Target	Quantify the target value.
	2. Co-Fi Remains	In the quantification process, if the weighing value $\geq$ the target value - Coarse Flow Remains, Coarse Fill is turned off.
	3. Me-Fi Remains	In the quantification process, if the weighing value $\geq$ the target value - Medium Flow Remains, Medium Fill is turned off.
	4.Free Fall	In the quantification process, if the weighing value $\geq$ the target value – Free Fall, Fine fill is turned off.
	5. Near Zero Band	In the quantification process, if the weighing value $\leq$ Near Zero Band, Discharge Delay Timer is started.
	6. COMP. Inhibit	At the beginning of the value, in order to avoid overshooting without weight judgment during this time, Co-F has been

	Timer(Co-F)	effective.Initial value: 0.9;Range: 0.0~99.9.(unit: s)
	7. COMP. Inhibit Timer(Me-F)	After the end of Co-F, in this period of time, in order to avoid overcharging without weight judgment, Me-F has been effective.Initial value: 0.9;Range: 0.0~99.9.(unit: s)
	8.COMP. Inhibit Timer(Fi-F)	After Me-F, in this period of time, in order to avoid overcharging without weight judgment, Fi-F has been effective.Initial value: 0.9;Range: 0.0~99.9.(unit: s)
	9.Current Filler Motor Cfg ID	Set the corresponding motor unit number. Initial value: 0;Range: 0~4.
Process Parameter	Used to set the delay timer related parameters of the filling process	
	1.Filling Pre-Delay Timer	In net weigher mode, when the quantification process starts,after the delay time, the controller will stable and zeroing (if it does not meet the Zero Interval condition, it will not stable and not zeroing), and then start the filling process; In gross weigher mode, after lock bag is finished, after the delay time, the controller is to be stable and tare. Initial value: <b>0.5</b> ; Range: <b>0.0~99.9</b> . (Unit: s )
	2. Result Waiting Timer	Result Checking Mode chose “Delay Timer”, after the fine filling is turned off (or the Over/Under is turned on, the Over/Under alarm is finished), quantification process is started, and the holding time is passed, and the quantification process is finished, enter to next process. Initial value: <b>0.5</b> ; Range: <b>0.0~ 99.9</b> . (Unit: s)
	3. Bag Locked Delay Timer	After the clutch bag signal is given, after the delay, controller judges that the bagging operation is completed. Initial value: <b>0.5</b> ; Range: <b>0.0~99.9</b> . (Unit: s )
	4. Unlock Bag Pre-Delay Timer	After net weigher mode discharge is completed, the unlock bag signal is output after the delay time; After the no hopper mode setting (patting bag) is completed, the unlock bag signal is output after this delay. Initial value: <b>0.5</b> ; Range: <b>0.0~99.9</b> . (Unit: s )
	5. DISC Delay Timer	During the discharge process, when the weight value of the weighing hopper is less than the Near Zero Band, the delay is started, when delay time is finished, discharge signal is closed. Initial value: <b>0.5</b> ; Range: <b>0.0~99.9</b> . (Unit: s ) (Note: This parameter is only valid for net weigher mode)
	6. Fill PreZero Interval	How many times the packaging process has been completed and then reset once.When entering the running state, the controller is not reset during the first packaging process. Initial value: 0; Range: 0 ~ 99. (Note: This parameter is only valid for net weigher mode)
	7.Next Filling Lock Bag PreDelay	Gross weigher interlock mode is effective. When scale A is at the front end of the conveyor and scale B is at the rear end of the rear conveyor, and the double scale bag release mode

		is not simultaneously released. If the bag is loosened by scale B after the feeding is completed, and scale A has not loosened the bag yet, then scale B will clamp another bag. After scale A completes the feeding and loosens the bag, and the conveyor starts, scale B will start feeding after a delay of this time. Initial value: <b>4.0</b> ; range: <b>0.0~99.9 (s)</b> (Note: This parameter is only valid when the bag is loosened at different times.)
	8.Result Check Mode	Wait Stable: After the fi-fo is turned off, the weight is stabilized and the set value process is completed. Time Delay: After the fi-fo is turned off, the fixed value is completed after the fixed value is maintained. Initial value: Wait Stable.
	9. Result Hold	On/Off is optional; set to “On”, the weight display remains unchanged after the end of the set time, and the weight changes again after the discharge starts. Initial value: off.
	10. Manual DISC To ACUM	On/Off is optional; set to “On”, The weight value of dynamic unloading shall be included in the cumulative value. Initial value: off. (Note: This parameter is only valid for the net weigher mode.)
	Used to set adaptive relevant parameter	
Adaptive	1.Adaptive Switch	Adaptive function, automatically adjust the coarse, medium and fine speed of the controller in the running process after the switch is turned on. Optional off, 2-Speed Fill, 3-Speed Fill. Initial value: off. (Note: 1. All Remains must be zero before normal use. 2. If Auto Free Fall Correction and the adaptive function are opened at the same time, the Auto Free Fall Correction will be closed forcibly.)
	2.Adaptive Level	The higher the level, the coarser the filling speed, the lower the accuracy. Initial value: 3; Range: 1 ~ 5.
	3.Permanent Replace Switch	When opened, the change value of Coarse, Medium, Fine Flow Remains will be updated to the value of quantitative parameter; When off, quantitative parameter values cannot be updated.
	Used to set Auto Free Fall Correction relevant parameters	
FreeFall Correction	1. FreeFall Correction	The drop value is the weight value that has not fallen into the measuring hopper after the fine filling signal is turned off. The drop correction is corrected according to the actual blanking value as required. (Note: If the freefall correction and adaptive functions are turned on at the same time, the drop correction function is invalid)
	2. Reference Samples PCS	The controller averages the difference of the set number of times as the basis for the drop correction. Initial value: <b>1</b> ; Range: <b>1 to 99</b> .



	3. Correction Effective Range	The controller averages the difference of the set number of times as the basis for the drop correction. Initial value: <b>2.0</b> ; Range: <b>0 to 9.9</b> (Percent of the target).
	4. Correction Percentage	The magnitude of each drop correction. Three ranges are available in <b>100% , 50% , and 25% .</b> Initial value: <b>50 % .</b>
<b>Over/Under Check</b>	Used to set Over/Under relevant alarm parameter	
	1.Over/Under Check	“On / Off” is optional. When this parameter is set to “On”, the quantification process judges the Over/Under.
	2. Over/Under Pause	“On / Off” is optional. When it is set to “On”, when the quantitative process is over or under, controller pauses and waits for the user to process. I/O Module enter Emergency Stop, returns to the stop state, and clear alarm; or I/O Module enter clear alarm, continue quantitative process.
	3.Over/Under Alarm Timer	The over/under check switch is turned on. After the " Result Waiting Timer "is over, the weighing hopper stabilizes, performs over/under tolerance detection, and outputs an over/under alarm time. After the time is over, discharging begins. Initial value: <b>1.0s</b> ; range <b>0.0~99.9</b> . (unit:s )
	4. Over Limit Value	In the quantification process, if the weighing value $\geq$ the target value + Over value, it is judged as Over. Initial value: <b>0</b> .
	5. Under Limit Value	In the quantification process, if the weighing value $\leq$ target value – Under value, it is judged as Under. Initial value: <b>0</b> .
	6. Fill Compensation	Set the Compensation ON/OFF On: Finely add the fill according to the number of fills. Off: Do not replenish when there is a shortfall.
	7.Fill-ON Timer	When filling the output, the effective time is added finely during an on-off cycle . Initial value : <b>0.5</b> ; range: <b>0.0 to 99.9</b> . (unit:s )
	8. Fill-OFF Timer	During the replenishment output, there is a slow addition of ineffective time within one on-off cycle. Initial value : <b>0.5</b> ; range: <b>0.0 to 99.9</b> . (unit:s )
	9. Compensation Times	When the quantitative process is judged to be inferior, the fill is finely added according to this value. Initial value: <b>1</b> ; range <b>1~99</b> .
<b>Jog Flow Parameter</b>	Used to set manual fine filling related parameters	
	1. Jog Flow ON/OFF	“On / Off” is optional. When set to “On”, the controller is finely added and jogged. Initial value: off.
	2. Jog Flow-ON Timer	When the jog output is finely added, the effective time is added finely during an on-off cycle . Initial value : <b>0.5</b> ; range: <b>0.0 to 9.9</b> . (unit s)

	<b>3. Jop Flow-on Timer</b>	When the jog output is finely added, the inactive period is finely added during an on-off period . Initial value : <b>0.5</b> ; range: <b>0.0 to 9.9</b> . (unit s)
Fast Mode ON/OFF	Used to set fast mode related parameters	
	<b>1. Fast Mode ON/OFF</b>	“ON/OFF” is optional, and setting it to " On "will activate the instrument panel's fast mode function. Initial value: OFF。
	<b>2.Fast Mode Timer</b>	Fast mode deadline. Initial value: <b>50</b> ; Range: <b>0~1000</b> 。 (Unit: ms)
	<b>3.Fast Mode Weight</b>	Fast mode cut-off weight value A. Range: 0~Full Capacity, Initial value: 0
	<b>4.Fast Mode Correction</b>	Automatically adjust the number of times using fast mode. Initial value: <b>5</b> ; Range: <b>0~10</b> 。
	<b>5.Stabilization Timer</b>	After activating the fast mode function, the instrument will stabilize the weighing time. Initial value: <b>100</b> ; Range: <b>0~1000</b> 。 (Unit: ms)

#### 4.2.1 Scale body structure parameters

The controller provides 5 kinds of scale structure, Net Weigher, Gross Weigher, Jumbo Bag, Valve Scale and PLC mode. Select different scale structure, the formula parameters show different parameters, the specific scale structure parameters are shown as follows.

Hopper Scale Parameter	Used to set the relevant parameters of with hopper scale mode	
	<b>1. Filling Combination Times</b>	When there is a hopper scale structure, the unlock bag is unloaded several times. If it is <b>0</b> , the controller discharges directly after the filling is completed without judging whether the pocket is valid. Initial value: <b>1</b> ; Range: <b>0 to 99</b> 。
	<b>2.Total Target Value</b>	Total quantitative target value (the total target value takes effect when the binyes multi-scale switch is turned on. For example, if the total target value is 100kg and the target value is 10kg, then the instrument measures 10kg each time, discharges about 10 times, and the total number of unloading and bagging times is 100kg (the target value of the last scale will be modified based on the cumulative value of the previous scale). When the total target value is less than the target value, start the scale with the target value as the final target value. Initial value: <b>0</b> ; Range: 0 to Full capacity.
	<b>3. Binyes Multi-scale Switch</b>	The "on/off" option is available, and if set to "on", the instrument will work in the bucket and multi scale mode. Initial value: Off. After activation, refer to the parameter description of the ton bag scale for parameter instructions.
	Holder Moveme	Optional: Air Without Limit/Motor(Two Limit)/Air( Two Limit); Initial value: Air

		nt Type	Without Limit
	4.Binyes Multi-scale Property Settings	Hanging Bag Reverse Logic	On/off optional; Set to 'on', in the mode of binyes multi-scale , when the hanging bag output is valid, the switch output is invalid. When the hanging bag output is invalid, the switch output is valid. Initial value: Off.
		Hanging Bag Control	On/off optional; Set to "open", in binyes multi-scale mode, after starting, allow the lifting bag, do not allow to remove the lifting bag. Initial value: Off.
Non-Hopper Scale Parameter	1.Holder Control	Optional:Auto Up And Down, Auto Up Manual Down, Manual Up Auto Down, Manual Up Manual Down; Initial value: Auto Up And Down.	
	2. Holder Up Timer	In gross weigher mode, this delay is performed after the rise signal is issued. Initial value: <b>0.0</b> ;range: <b>0~99.9</b> . ( unit s ) (Note: The parameters are visible in the "Air Without Limit" mode of the holder movement type in the scale structure.)	
	3. Holder Down Timer	In gross weigher mode, the delay is activated after the quantitative delay is over. Initial value: <b>0.0</b> ;range: <b>0~99.9</b> . ( unit s ) (Note: The parameters are visible in the "Air Without Limit" mode of the holder movement type in the scale structure.)	
	4.Holder Up OverTime	When the metering bracket is ascending, the ascending output of the metering bracket is effective, while the descending output of the metering bracket is invalid. Wait until the bracket is ascending in place. If the bracket is still not ascending in place within the timeout period of the bracket ascending, the bracket ascending timeout alarm will be given. Initial value: <b>5.0</b> ;range: <b>0~99.9</b> . ( unit s ) (Note: The parameters are visible in the "Motor(Two Limit)/Air(Two Limit)" mode of the holder movement type in the scale structure.)	
	5. Holder Down OverTime	When the metering support is descending, the metering support's descending output is effective, while the metering support's ascending output is invalid. Wait until the support is descending in place. If the support is still not descending in place within the timeout time of the support descending, the support's ascending timeout alarm will be given. Initial value: <b>5.0</b> ;range: <b>0~99.9</b> . ( unit s ) (Note: The parameters are visible in the " Motor(Two Limit) /Air(Two Limit)" mode of the holder movement type in the scale structure.)	
	6.Bag Lost Detect Time	Used to detect whether the bag is detached from the bag holding mechanism. After starting to feed, after	

		[ Bag Lost Detect Time], if the current weight is still lower than [ Bag Lost Detect Weight], the instrument will alarm to stop (the bag may fall off at this time). If either of the two parameters is set to 0, the function is disabled. Initial value: <b>0</b> ;range: <b>0~99.9</b> . ( unit s)
	7..Bag Lost Detect Weight	After starting to feed, after [ Bag Lost Detect Time ], if the current weight is still lower than [ Bag Lost Detect Weight ], the instrument will alarm to stop (the bag may fall off at this time). Initial value: <b>0</b> ; Range: 0 to Full capacity.
Ton Scale Parameter	Used to set the relevant parameters of ton bag scale mode	
	1. Hang Up Bag Delay	The bag delay time until the bag is completed . Initial value : <b>0.5</b> ; range: <b>0.0 to 99.9</b> . (unit s)
	2. Blowing Mode	<b>Air Blow Before Up Delay:</b> air blow output valid,hanger rise output is valid. <b>Air Blow After Up Delay:</b> after hanger output continue hanger rise delay time starts air blow. Initial value: Air Blow Before Up Delay.
	3.Air Blow Timer	Blowing timer Initial value: <b>0.5</b> ; range: <b>0.0~99.9</b> . (unit s)
	4. Rlief Valve Mode	OFF After Filling: after closing the fine fill, the return valve output is invalid. OFF After Bag Unlock: return valve output is invalid after bag unlocking. Initial value: Close the return valve after filling.
	5. Hang Up Bag Time	When the parameter is not set to 0, after filling is completed, the output of the bag is invalid and continues to be valid after this time. Initial value: 0.0;Range: 0.0 ~ 99.9.(unit s) Note: ①the reset time of the lifting bag shall be longer than the delay time of the lifting bag before the reset is valid. ②Controller operation first scale needs to manually give a bag signal. ③ Parameter is set to 0, controller before each start charging, need punching bag signal.
	6.Holder Control	Optional:Auto Up And Down, Auto Up Manual Down, Manual Up Auto Down, Manual Up Manual Down; Initial value: Auto Up And Down.
	7. Holder Up Timer	In gross weigher mode, this delay is performed after the rise signal is issued. Initial value: <b>0.0</b> ;range: <b>0~99.9</b> . ( unit s) (Note: The parameters are visible in the "Air Without Limit" mode of the holder movement type in the scale structure.)
	8. Holder Down Timer	In gross weigher mode, the delay is activated after the quantitative delay is over.

		Initial value: <b>0.0</b> ;range: <b>0~99.9</b> . ( unit s ) (Note: The parameters are visible in the "Air Without Limit" mode of the holder movement type in the scale structure.)
	<b>9.Holder Up OverTime</b>	When the metering bracket is ascending, the ascending output of the metering bracket is effective, while the descending output of the metering bracket is invalid. Wait until the bracket is ascending in place. If the bracket is still not ascending in place within the timeout period of the bracket ascending, the bracket ascending timeout alarm will be given. Initial value: <b>5.0</b> ;range: <b>0~99.9</b> . ( unit s ) (Note: The parameters are visible in the "Motor(Two Limit)/Air(Two Limit)" mode of the holder movement type in the scale structure.)
	<b>10. Holder Down OverTime</b>	When the metering support is descending, the metering support's descending output is effective, while the metering support's ascending output is invalid. Wait until the support is descending in place. If the support is still not descending in place within the timeout time of the support descending, the support's ascending timeout alarm will be given. Initial value: <b>5.0</b> ;range: <b>0~99.9</b> . ( unit s ) (Note: The parameters are visible in the " Motor(Two Limit) /Air(Two Limit)" mode of the holder movement type in the scale structure.)
<b>11. Lift Bag For Release</b>	<b>a. Hook Up For Release</b>	ON: When is on. OFF: When is off. Initial value:OFF
	<b>b. Pre-Delay of Hook Up</b>	When is on, after decoupl, need to delay the time hanger to rise. Initial value:0.0s Range: 0.0~99.9 (unit s)
	<b>c. Hook Up Time</b>	When the rise I/O is on and the rise support output needs to last for this time after the rise is executed Initial value:0.0s Range: 0.0~99.9 (unit s)
	<b>d. Hook Up pause time</b>	When the rise I/O is on, and after the decoupling rise is over, it is necessary to wait for the time before descending. Initial value:0.0s Range: 0.0~99.9 (unit s)
<b>12. Release Uncompletely Alarm</b>	<b>a. Bag Not Release Completely</b>	ON:Unhook incomplete alarm switch on. OFF: Unhook incomplete alarm switch off. Initial value: OFF.
	<b>b. Conveyor REV. Time(If Bag Hung)</b>	The uncoupled alarm I/O is on. When the uncoupled alarm is complete, the conveyor will perform the reversal immediately for the duration. Initial value:0.0s Range: 0.0~99.9 (unit s) (Set to 0: means the conveyor does not reverse)

		<b>c. Weight For Bag Release Check</b>	The uncoupled alarm I/O is on. If the current weight is greater than the value of the decoupling alarm during the period of decoupling ascending, controller will output the decoupling alarm signal. Initial value:0, range: 0~Maximum range
Valve Scale Parameter	Used to set the valve scale mode related parameters		
	1. Bag Lift Delay	The delay time before the bag is started at the same time when the unlock bag starts to start . Initial value : <b>0.5</b> ; range: <b>0.0 to 99.9</b> . (unit s)	
	2. Bag Lift Timer	The time is started after the delay timebefore the bag is lifted , and the bag signal output is valid. After the time is over, the bag signal output is invalid. Initial value : <b>0.5</b> ; range: <b>0.0 to 99.9</b> . (unit s)	
	3. Bag Push Delay	When the unlock bag start delay starts, the delay time before pushing the bag is started at the same time. Initial value : <b>0.5</b> ; range: <b>0.0 to 99.9</b> . (unit s)	
	4. Bag Push Timer	The time is started after the delay timebefore pushing the bag , and the push bag signal output is valid. After the time is over, the push bag signal output is invalid . Initial value : <b>0.5</b> ; range: <b>0.0 to 99.9</b> . (unit s)	
	5.Bag Lost Detect Time	Used to detect whether the bag is detached from the bag holding mechanism. After starting to feed, after [ Bag Lost Detect Time], if the current weight is still lower than [ Bag Lost Detect Weight], the instrument will alarm to stop (the bag may fall off at this time). If either of the two parameters is set to 0, the function is disabled. Initial value: <b>0</b> ;range: <b>0~99.9</b> . ( unit s)	
	6..Bag Lost Detect Weight	After starting to feed, after [ Bag Lost Detect Time ], if the current weight is still lower than [ Bag Lost Detect Weight ], the instrument will alarm to stop (the bag may fall off at this time). Initial value: <b>0</b> ; Range: 0 to Full capacity.	
PLC parameter	Used to set PLC mode related parameters		
	1. Target	Quantify the target value.	
	2. Co-Fi Remains	In the quantification process, if the weighing value $\geq$ the target value - Coarse Flow Remains, Coarse Fill is turned off.	
	3. Me-Fi Remains	In the quantification process, if the weighing value $\geq$ the target value - Medium Flow Remains, Medium Fill is turned off.	
	4.Free Fall	In the quantification process, if the weighing value $\geq$ the target value – Free Fall, Fine fill is turned off.	
	5. Near Zero Band	In the quantification process, if the weighing value	

	≤Near Zero Band, Discharge Delay Timer is started.
<b>6. Over Limit Value</b>	When the weighing value > target value + excess value, the out-of-tolerance output is valid Initial value: <b>0.00</b> ; range: <b>0.00~100.00</b> .
<b>7. Under Limit Value</b>	When the weighing value <target value - under-difference, the under-output is valid Initial value: <b>0.00</b> ; range: <b>0.00~100.00</b> .
<b>8. Upper Limit Value</b>	When the weighing value > upper limit value, the upper limit output is valid Initial value: <b>0.00</b> ; range: <b>0.00~100.00</b> .
<b>9. Lower Limit Value</b>	When the weighing value is < lower limit, the lower limit output is valid. Initial value: <b>0.00</b> ; range: <b>0.00~100.00</b> .

### 4.3 Weight parameter

In the menu interface, click the **【Weight】** menu to enter the current parameter item to view and set the attribution parameter information.

Parameter	Description	
<b>1. Zero Range</b>	The range can be cleared . Initial value: <b>50</b> ; Range: <b>1 to 99</b> ( % of full scale) .	
<b>2. Stable Range / Time</b>	During the judgment time, the weight change range is within this set value and the controller judges that the scale is stable. Initial value: <b>2</b> ; Range: <b>0 to 99 (d)</b> . First value: <b>0.3</b> ; Range: <b>0.1 to 9.9</b> .	
<b>3.TrZero Range / Time</b>	The weight value is within this range and the controller is automatically cleared.When it is <b>0</b> , zero tracking is not performed. Initial value: <b>0</b> ; range: <b>0 to 9 (d)</b> . First Value: <b>20</b> ; range: <b>0.1- 99.9</b> . (unit s)	
<b>4.PWN-ON Zero</b>	On / off is optional. When it is “on”, the controller will automatically perform the clear operation when the power is turned on (the weight inside the scale bucket meets the clearing range). Initial value: off	
<b>5. Sample Rate</b>	A/D sampling rate. <b>120</b> times / sec, <b>240</b> times / sec, <b>480</b> times / sec, <b>960</b> times / sec. Initial value: <b>240</b> times / sec.	
<b>6. Digital Filter</b>	Classification of filtering strength in stopped state. Initial value: <b>7</b> ; range <b>0~9</b> .	
<b>7. Dynamic Filter Parameter</b>	<b>a. Dynamic Filter</b>	During the bagging process, whether to perform the filter operation ON/OFF and set “On”, the following three parameters are valid. Initial value: on.
	<b>b. Vib-Filter</b>	On/off optional, secondary filtering based on digital filtering. Initial value: off.

	c. Filling Filter	Filter parameters during filling: 9: The filtering effect is the strongest. Initial value: 4; Range: 0 to 9.
	d. Result Check Filter	Filter parameters during the setting process: 9: The filtering effect is the strongest. Initial value: 7; Range: 0 to 9.
	e. Discharge Filter	Filter parameters during unloading: 9: The filtering effect is the strongest. Initial value: 1; Range: 0 to 9.
8. Running Stable Timeout		Initial value: 0.0 ; range: 0.0~99.9 .(unit s )

## 4.4 System Maintenance

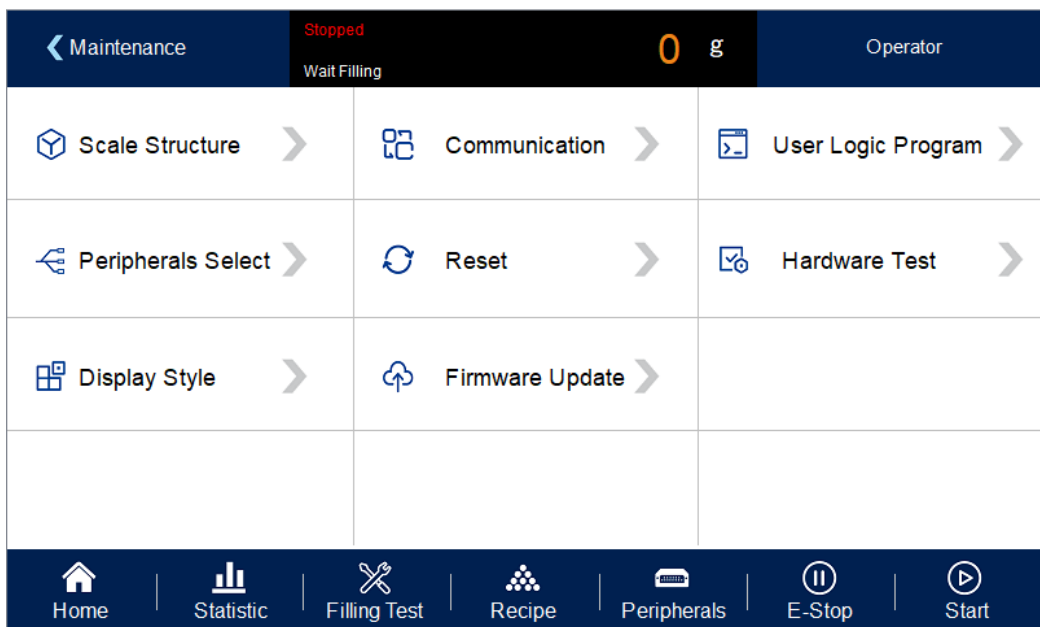

### 4.4.1 Scale structure

Parameter		Description
1. Scale Structure		There are Net Weigher / Gross Weigher/ Jumbo Bag / Valve Scale / PLC selection available. Initial value: Net Weigher. (Set corresponding parameters according to different scale structures.)
2. Net Weigher parameter setting	a. Working Mode	Optional single scale,Dual Scale:Master,Dual Scale:Slave. Initial value:Single Scale .
	b.Filling Ctrl Mode	<b>Single Ctrl/Combo Ctrl</b> is optional; Initial value: Combo Ctrl. <b>Combo Ctrl:</b> fast feeding large, medium and small feeding port at the same time; Add medium and small feeding port at the same time feeding; Slow time small feeding port



		feeding. <b>Single Ctrl:</b> fast and large feeding port feeding; Add when the feeding port feeding; Slow time small feeding port feeding.
	c. Fill Gate Mode	0.Air Drived; 1.Step Motor 2.Motor Drived
	d. Clamper Mode	0.Air Drived; 1.Step Motor; 2.MotorDrive Dual-Limit; 3.MotorDrive Single-Limit Default value: 0. Air Drived
	e. DISC Gate Mode	0.Air Drived mode; 1. Step Motor; 2. MotorDrive Dual-Limit;3. MotorDrive Single-Limit;; 4. Normal Motor Rotating Default value: 0 Air Drived
	f. Manual Unlock Bag	Optional on/off;Set to "on", in operation, need to manually control unlock bag. Initial value: OFF.
	g. DISC Gate Pos. Detect	Optional on/off;When "on" is selected, the limit signal is detected in real time;When "off", the limit signal is detected only when filling is started. Initial value: OFF. (Note: DISC Gate Mode is valid in motor mode)
	h. No Position Singal For Fill Gate	Initial value: off; OFF: The signal indicating the proper us of additives; ON: The addition of materials does not use the proper signal. (Note: The fill gate mode is step motor mode, and the parameters are visible)
	i. No Position Singal For Clamper	Initial value: OFF; OFF: Clamp the bag in place signal. ON: clamp the bag in place signal is not used. (Note: The clamper mode is step motor mode, and the parameters are visible)
	j. No Position Singal For DISC Gate	Initial value: OFF; OFF: Unloading door closing signal in place, ON: Unloading door closing signal not in place. (Note: The unloading mode is step motor mode, and the parameters are visible)
	k. Fill Gate Close Err	Initial value: OFF; OFF: Failure to detect in place signal during feeding process, ON: Detection of in place signal during feeding process (Note: If there is significant interference signal on site, it is recommended to turn off this alarm and the fill gate mode is step motor mode, and the parameters are visible)
3. Gross Weigher parameter setting	a. Working Mode	Optional single scale,Dual Scale:Master,Dual Scale:Slave. Initial value:Single Scale .
	b. G/N Packing	Gross Packing/Net Packing; Initial value: Net Packing
	c. Filling Ctrl Mode	<b>Single Ctrl/Combo Ctrl</b> is optional; Initial value: Combo Ctrl. <b>Combo Ctrl:</b> fast feeding large, medium and small feeding port at the same time; Add medium and small feeding port

		at the same time feeding; Slow time small feeding port feeding. <b>Single Ctrl:</b> fast and large feeding port feeding; Add when the feeding port feeding; Slow time small feeding port feeding.
	<b>d. Fill Gate Mode</b>	0.Air Drived; 1.Step Motor 2.Motor Drived
	<b>e. Clamper Mode</b>	0.Air Drived; 1.Step Motor; 2.MotorDrive Dual-Limit; 3.MotorDrive Single-Limit Default value: 0. Air Drived
	<b>f. Allow Unlock Bag When Fill</b>	Optional on/off;Set to "on", no bucket scale mode, after starting, it is allowed to unlock bags in filling.Set to "off". After starting, it is not allowed to unlock bags in filling Initial value: off.
	<b>g. Manual Unlock Bag</b>	Optional on/off; Set to "on", in operation, need to manually control unlock bag. Initial value: off.
	<b>h. Holder Control</b>	Optional on/off;Set to "on". In operation, the movement mode of the bracket needs to be controlled manually. Initial value: off.
	<b>i. Holder Movement Type</b>	Optional:Air Without Limit/Motor(Two Limit)/Air( Two Limit); Initial value: Air Without Limit (Note: Parameters can be seen when the support holder control switch is on)
	<b>j. Dual Scale Unlock Bag Mode</b>	Asynchro Unlock/Synchro Unlock1/ Synchro Unlock 2 are optional. Initial value: Asynchro Unlock. <b>Asynchro Unlock:</b> unlock bag after finishing packing, when A/B scales are all unlock bag, the controller controls the signal output of conveyor and starts the conveyor. <b>Synchro Unlock1:</b> in the normal mode, the filling of one scale has been completed and the filling of the other has not been completed. After the completion of the other scale, both scales are losing bag at the same time. If a scale has finished filling, the other scale is not in the bag (filling) state, then do not wait for another scale, this scale directly unlock bag. <b>Synchro Unlock 2:</b> for the coarse mode, this mode defaults to scale A in the front and scale B in the back.After filling, scale A will not judge whether B is finished or not, and will unlock the bag directly. After the completion of filling, B should judge whether A is in the state of bag clamping (filling). If A is filling, B should wait for A to finish adding and unlockn the bag.If A is not filling, B does not have to wait to unlock the bag. (Note: the working mode is Dual Scale:Master/ Dual Scale:Slave parameters can be seen.)

	<b>k. No Position Singal For Fill Gate</b>	Initial value: off; OFF: The signal indicating the proper use of additives; ON: The addition of materials does not use the proper signal. (Note: The fill gate mode is step motor mode, and the parameters are visible)
	<b>l. No Position Singal For Clamper</b>	Initial value: OFF; OFF: Clamp the bag in place signal. ON: clamp the bag in place signal is not used. (Note: The clamper mode is step motor mode, and the parameters are visible)
	<b>m. Fill Gate Close Err</b>	Initial value: OFF; OFF: Failure to detect in place signal during feeding process, ON: Detection of in place signal during feeding process (Note: If there is significant interference signal on site, it is recommended to turn off this alarm and the fill gate mode is step motor mode, and the parameters are visible)
4. Jumbo Bag parameter setting	<b>a.G/N Packing</b>	Gross Packing/Net Packing; Initial value: Net Packing
	<b>b. Filling Ctrl Mode</b>	<b>Single Ctrl/Combo Ctrl</b> is optional; Initial value: Combo Ctrl. <b>Combo Ctrl:</b> fast feeding large, medium and small feeding port at the same time; Add medium and small feeding port at the same time feeding; Slow time small feeding port feeding. <b>Single Ctrl:</b> fast and large feeding port feeding; Add when the feeding port feeding; Slow time small feeding port feeding.
	<b>c. Fill Gate Mode</b>	0.Air Drived; 1.Step Motor 2.Motor Drived
	<b>d. Clamper Mode</b>	0.Air Drived; 1.Step Motor; 2.MotorDrive Dual-Limit; 3.MotorDrive Single-Limit Default value: 0. Air Drived
	<b>e. No Position Singal For Fill Gate</b>	Initial value: off; OFF: The signal indicating the proper use of additives; ON: The addition of materials does not use the proper signal. (Note: The fill gate mode is step motor mode, and the parameters are visible)
	<b>f. No Position Singal For Clamper</b>	Initial value: OFF; OFF: Clamp the bag in place signal. ON: clamp the bag in place signal is not used. (Note: The clamper mode is step motor mode, and the parameters are visible)
	<b>g. Manual Unlock bag</b>	Optional on/off; Set to "on", in operation, need to manually control unlock bag. Initial value: off.
	<b>h. Holder Movement Type</b>	Optional: Air Without Limit/Motor(Two Limit)/Air( Two Limit); Initial value: Air Without Limit (Note: Parameters can be seen when the support holder control switch is on)
	<b>i. Hanging Bag Control</b>	Optional on/off; Set to "open", jumbo bag scale mode, after starting, allowed to lift bag, not allowed to take off the bag.

		Initial value: off.
	<b>j.</b> Hanging Bag Reverse Logic	Optional on/off;Set to "on", in the jumbo bag scale mode, when the bag output is effective, the output of switching quantity is invalid; when the bag output is invalid, the output of switching quantity is effective. Initial value: off.
	<b>k.</b> Tare Detect	Optional on/off; When set to "on", the controller will return to the stop state without filling to a fixed value in the operation of the controller. When it is started again, it does not need to remove the skin and start filling directly. (Note: This function will only record the tare value when the current weight is greater than 0 and it is started again.) Initial value: off.
	<b>l.</b> Fill Gate Close Err	Initial value: OFF; OFF: Failure to detect in place signal during feeding process, ON: Detection of in place signal during feeding process (Note: If there is significant interference signal on site, it is recommended to turn off this alarm and the fill gate mode is step motor mode, and the parameters are visible)
<b>5.</b> Valve Scale parameter setting	<b>a.</b> G/N Packing	Gross Packing/Net Packing; Initial value: Net Packing
	<b>b.</b> Filling Ctrl Mode	<b>Single Ctrl/Combo Ctrl</b> is optional; Initial value: Combo Ctrl. <b>Combo Ctrl:</b> fast feeding large, medium and small feeding port at the same time; Add medium and small feeding port at the same time feeding; Slow time small feeding port feeding. <b>Single Ctrl:</b> fast and large feeding port feeding; Add when the feeding port feeding; Slow time small feeding port feeding.
	<b>c.</b> Fill Gate Mode	0.Air Drived; 1.Step Motor 2.Motor Drived
	<b>d.</b> Clamper Mode	0.Air Drived; 1.Step Motor; 2.MotorDrive Dual-Limit; 3.MotorDrive Single-Limit Default value: 0. Air Drived
	<b>c.</b> Manual Unlock bag	Optional on/off; Set to "on", in operation, need to manually control unlock bag. Initial value: off.
	<b>d.</b> No Position Singal For Fill Gate	Initial value: off; OFF: The signal indicating the proper use of additives; ON: The addition of materials does not use the proper signal. (Note: The fill gate mode is step motor mode, and the parameters are visible)
	<b>e.</b> No Position Singal For Clamper	Initial value: OFF; OFF: Clamp the bag in place signal. ON: clamp the bag in place signal is not used. (Note: The clamper mode is step motor mode, and the parameters are visible)

	f. Fill Gate Close Err	Initial value: OFF; OFF: Failure to detect in place signal during feeding process, ON: Detection of in place signal during feeding process (Note: If there is significant interference signal on site, it is recommended to turn off this alarm and the fill gate mode is step motor mode, and the parameters are visible)
<b>6.Slider Mode</b>	For Step motor mode; When the traction machine of the peripheral select in maintenance is set to "Built-in Tractor", the parameters are visible and cannot be modified.	
<b>7.Clamping Arm LockMode</b>		

#### 4.4.2 Communication Setting

**GM9907** Two serial communication interfaces can be provided. See Section 2.5 for the definition of serial port output; correct setting of port parameters can be used for communication.

Communication Parameter	Parameter	Description
Serial port (Serial port 1 (232), Serial port 2 (485) )	<b>1. Communication ID</b>	Initial value: <b>1</b> ; <b>1~99</b> optional.
	<b>2. Protocol</b>	Initial value: <b>Modbus-RTU</b> . <b>Modbus-RTU / Print /Self-Sending Mode / Modbus 8802S-P/Re-Cont</b> is optional.
	<b>3. Baudrate</b>	Initial value: <b>38400</b> ; <b>9600/19200/38400/57600/115200</b> optional.
	<b>4. Data Format</b>	Initial value: <b>8-E-1</b> ( <b>8</b> -bit data bit -even parity - <b>1</b> stop bit ) ; <b>8-E-1/8-N-1/7-E-1/7-N-1</b> is optional.
	<b>5. Dword Format</b>	<b>Modbus</b> communication display mode: Initial value: <b>AB-CD</b> (high word first); <b>AB-CD</b> (high word first) / <b>CD-AB</b> (low word first) optional.
Ethernet	<b>1. Protocol</b>	Fix: <b>Modbus-TCP</b> .
	<b>2. Modbus-TCP Dword Format</b>	Initial value <b>AB-CD</b> . Range: <b>AB-CD</b> (high word first) <b>CD-AB</b> (low word first)
	<b>3. Server Port</b>	Initial value: <b>502</b> , Range: <b>1~65535</b>
	<b>4. IP</b>	Initial value: <b>192</b> ,Range: <b>0~255</b>
		Initial value: <b>168</b> , Range: <b>0~255</b>
		Initial value: <b>101</b> , Range: <b>0~255</b>
<b>5. MAC</b>	Initial value: <b>246</b> , Range: <b>0~255</b> <b>BC.66.41.9x.xx.xx</b> .	
Print	<b>1. Auto Print</b>	On/Off is optional; when “On” is selected, the package result will be printed out automatically every time the package is completed (the serial port should be selected as “Print”).

	Initial value: off.
<b>2. Printer Format</b>	Initial value: <b>24</b> Columns Printing; <b>24</b> Columns Printing / <b>32</b> Columns Printing
<b>3. Print Language</b>	Initial value: Chinese;Chinese/ English optional.
<b>4. Print Empty Line Nos.</b>	The number of lines after the print is completed. Initial value: <b>3</b> ; <b>0~9</b> optional.

#### 4.4.3 User Logic Program

Auxiliary logic programming function, up to 6 sets of auxiliary logic trigger signals can be defined, and the effective time and output port after the auxiliary logic signal is triggered can be set. The simple logic signal output can be configured to control other auxiliary devices, and 6 sets of auxiliary logic signals. They can also control each other. Under the auxiliary logic programming interface.

Auxiliary logic(1~ 6) Programming parameter	parameter	Description
<b>1. User Logic Type</b>	Disable	The type of auxiliary logic programming signal is selected based on the logic to be implemented.
	Delay ON	
	Delay Off	
	Delay ON & OFF	
	OFF To ON Edge Trigger	
	ON To OFF Edge Trigger	
<b>2. Logic Trig ger Type</b>	By Trigger Function (default)	After setting any of the <b>1~ 12</b> channels as the trigger signal, the input port will be fixed as the trigger signal.
	<b>Input -1~12</b>	Set any of the <b>1~ 12</b> input ports as the trigger signal, then the input can be either the trigger signal or the function signal of the input port.
	I/O Module output define	After the trigger signal is set to “an internal function signal”, the trigger output is performed according to the function signal.
	<b>&gt; = or &lt; = weight Value Trigger</b>	After the trigger condition is set , the current weight value is compared with the set weight threshold , and the output is triggered when the condition is met .
<b>3. Trigger Function(IN)</b>	<b>IN1~12</b>	Initial value: no definition. Select the digital input port corresponding to the function signal. The input port “ <b>0</b> is not defined” means that the function is not defined.

4. Trigger Function(OUT)	OUT1~16	Initial value: no definition. Select the digital output port corresponding to the function signal. The output port "0 is not defined" means that the function is not defined.
5. Delay ON Timer	Unit s	Initial value: 0.0 ; Range: 0.0~99.9 . After the trigger signal is valid, the logic output signal is valid after the delay.
6. Delay OFF Timer	Unit s	Initial value: 0.0 ; Range: 0.0~99.9 . After the trigger signal is invalid, the logic output signal will be invalid after the delay.
7. Output ON Timer	Unit s	Initial value: 0.0 ; Range: 0.0~99.9 . The duration after the logic output signal is valid, and becomes invalid after the end of the time.
8. Logic Trigger Weight	Consistent with the calibration unit	Initial value: 0.0 ; Range: 0.0~ Maximum range . Set the weight value, the current weight and the threshold weight comparison , and trigger when the weight value trigger condition is met .(When the trigger select "> =", or "<=weight value" valid).

#### Delay ON

- When the delay is turned on [By Trigger Function], the operation is as follows:
  1. Set parameters and I/O Module: type select **【Delay ON】**, if choose **【By Trigger Function】** trigger input port is defined as "1" (I/O Module input port 1 is shown as "auxiliary logic trigger input 1"), logic output port is defined as "1" (I/O Module output port 1 is shown as "auxiliary logic output 1"), set **【Delay ON Time】** for 2 seconds.
  2. Execute operation: make the trigger signal input 1 valid, start the delay delay on time, and continue to be valid until the delay on time 2s ends, the logic output signal port 1 output is valid until the trigger signal input 1 is invalid, the logic output Signal port 1 also becomes invalid. See the timing diagram below:
  
- When selected to delay on **【Input Port 1-12】** , operation is as follows,
  1. Set parameters and I/O Module: trigger signal choose "input port 1 "(can see I/O Module input port 1 is shown as " the definition of the original unchanged", assuming the original definition is started, the function of the input port 1 can be" started "or" signals trigger"), logic output port is defined as 1 (can see the I/O Module output port 1 is shown as" auxiliary logic output 1 "), set the **【Delay ON Time】** as 2 seconds.
  2. Execution operation: make the trigger signal input 1 valid (starting is also valid, the controller running output is valid), start the delay-on time, and remain valid until the delay-on time is 2s , the logic output signal port 1 output is valid. Until the trigger signal input 1 is invalid, the logic output signal port 1 also becomes invalid. The controller will continue to run until an emergency stop signal is given.
  
- When select delay on I/O Module output define, operation is as follows,
  1. Set parameters and I/O Module: trigger signal is "run" (I/O Module output can be defined or not), the logic output port is defined as 1 (can see the I/O Module output port 1 is shown as auxiliary logic output 1), and the **【Delay On Timer】** is set to 2 seconds.
  2. Execution operation: After the external input "start", when the "run" output signal is valid, it starts to go [delayed on time], and remains valid until the end of the delay on time 2s , the

output of the logic output signal port 1 is valid. The logic output signal port 1 becomes invalid until the "Emergency stop or pause" is valid and the "Run" output signal is invalid.

● When select delay on  $\geq$  or  $\leq$  weight value trigger, operation is as follows:

1. Set the corresponding threshold weight, logic output port is defined as 1 (it can be seen that the output port 1 of the I/O Module is shown as the auxiliary logical output 1), and the **【Delay ON Timer】** is set to 2 seconds.

2. Execution operation: current weight value  $\geq$  or  $\leq$  logic1 threshold weight is valid when setting value, start to go [delay on time], it is valid until the end of delay on time 2s, logic output signal port 1 The output is valid until the current weight  $<$  or  $>$  logic 1 threshold weight setting value is invalid for logic output signal port 1 .

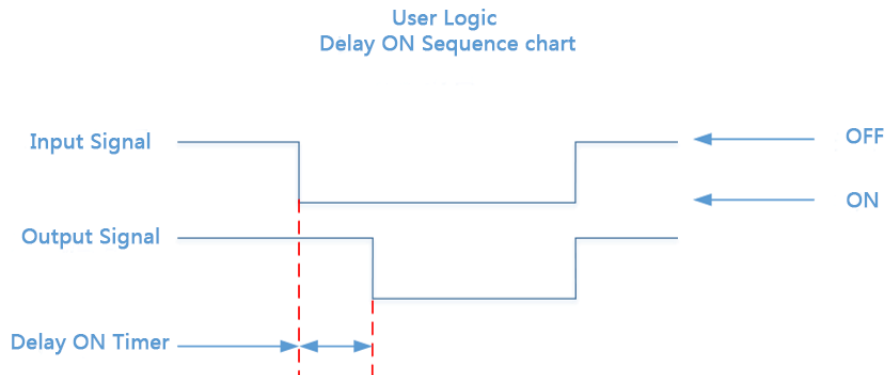

#### Delay OFF

Relevant parameters : type selections**【Delay OFF】**,choose**【Trigger Type】**, set**【Trigger input port】** , **【Logic output port define】** , **【Delay OFF Timer】** . Operations refer to “Delay ON”. Output functions as below:

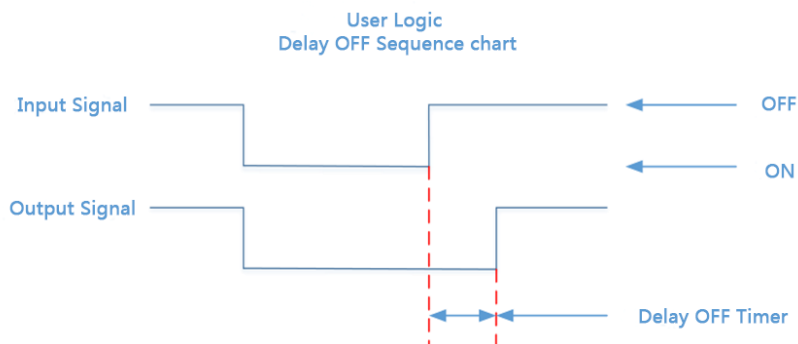

#### 4.4.3.3 Delay ON & OFF

Relevant parameters : type selections **【Delay ON&OFF】** ,choose **【Trigger Type】** ,set **【Trigger input port】** ,**【Logic output port define】** , **【Delay ON】** , **【Delay OFF】** . Operations refer to “Delay ON”. Output functions as below:



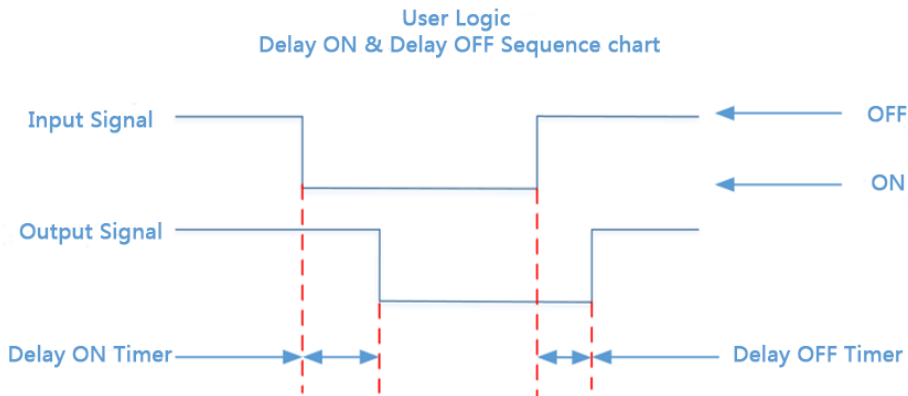

### OFF To ON Edge Trigger

Related parameters: Type selection [OFF To ON Edge Trigger], select [Logic Trigger Type], set [Trigger Function(IN)], [Trigger Function(OUT)], [Delay ON Timer]. Operation Reference " Delay ON ",Its output function is shown below:

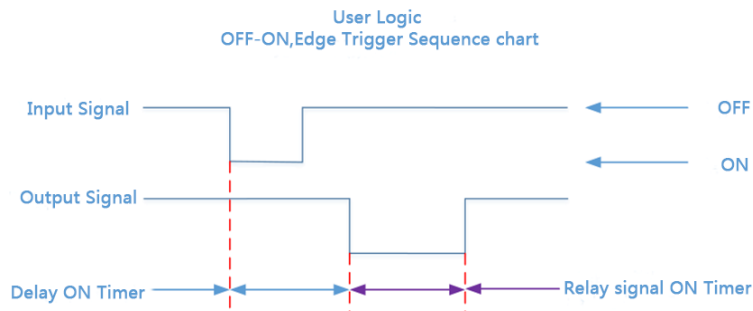

### ON To OFF Edge Trigger

Related parameters: Type selection [ON To OFF Edge Trigger], select [Logic Trigger Type], set [Trigger Function(IN)],[Trigger Function(OUT)],[Delay ON Timer]. Operation Reference "3.8 .1-Delay." Its output function is shown below:

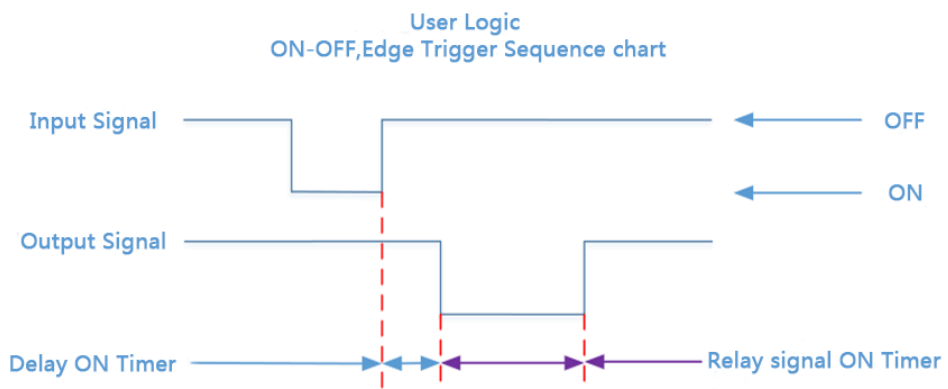

#### 4.4.4 Peripherals Select parameters

This parameter sets the switch of controller peripheral. If set on, peripheral parameters of the main interface can be set. Refer to Chapter 4.5 for specific peripheral parameters.

Parameter	Description
1. Patting Mode	<p>Patting Bag mode selection; Initial value: Disable. Optional: <b>Net Weigher mode:</b> Disable/When Hold(patting bag after fixed value)/When Filling/All Time is optional (Note:When the multi scale switch is turned on, When Filling and All Time is optional) <b>Gross Weigher mode:</b> Disable/When Hold(patting bag after fixed value)/When Filling/All Time is optional; <b>Jumbo Bag mode:</b> Disable/When Hold(patting bag after fixed value)/When Filling/All Time is optional <b>Valve Scale mode:</b> Disable/When Hold(patting bag after fixed value)/When Filling/All Time is optional <b>PLC mode:</b> No peripheral functions available</p>
Sewing Device	Whether to turn on the function of bale sewing machine.Optional on and off. When open, the peripheral can start to sew the bag, and the parameters of the sew machine can be set.
Conveyor	<p>Selection of conveyor mode: Initial value: Disable <b>Gross Weigher /Valve Scale mode:</b> Disable /1 Conveyor optional; <b>Net Weigher /Jumbo Bag scale mode:</b> Disable /1 Conveyor/2 Conveyor /3 Conveyor optional. (Note:When the multi scale switch is turned on, 2 Conveyor /3 Conveyor is optional)</p>
Coding Device	Whether to enable the coding function.On and off are optional. When on, the peripheral starts coding function and the coding parameters can be set.
DISC Shaking Mode	Whether to open the discharge shaking switch.Optional :Disable,Individual Shaking ,DISC Shaking. When set to individual Shaking and DISC Shaking , the external device enables the discharge vibration function, and the discharge vibration parameters can be set.
Aux. Pulse Switch	Whether to enable auxiliary pulse function.On and off are optional. When on, this function is enabled by peripheral and auxiliary pulse parameters can be set.
Fill&DISC Monitor	Whether to turn on the timeout alarm function of Fill/Discharge .On and off are optional. When on, this function is enabled by peripheral and timeout alarm parameter can be set.
Tractor	<p>Tractor selection:Disable, Built-in Tractor Initial value: :Disable (Tractor parameters do not work when you select disable) Parameters can be set after selecting the built-in tractor . (Note: When the scale structure is in net weigher or gross weigher mode, the parameters are visible)</p>

#### 4.4.5 Reset

Administrators can restore and backup data through the recovery factory in **【Maintenance】**.

1. Reset All (Except Calibration)	Click this item to restore all parameters of the controller (except calibration parameters) to factory setting values.
2. Reset All	Click this to restore all the parameter values of the controller to the factory settings.
3. Reset Calibration	Click this to restore the calibration scale parameter value to the factory setting value.
4. Reset Weight	Click this to reset weight and scale structure parameter as factory setting.
5. Reset Recipe	Click this to restore the recipe parameter value to the factory setting.
6. Reset Communication	Click this item to restore communication setting parameter value is factory setting value.
7. Reset Peripherals	Click this item to restore peripheral parameter values and peripheral switch to factory setting values.
8. Reset Motor	Click this item to restore motor parameter value to factory setting value.
9. Reset I/O Function	Click this item to restore I/O Function to factory setting value.
10. Reset User Logic	Click this item to restore logic edit parameter to factory setting value.
11. Parameter Backup	Click controller to backup the current parameter setting values.
12. Recovery From Backup	Click controller to restore the parameter value to the most recent backup value.
13. Delete Backup	Click controller to delete the backup parameters.

#### 4.4.6 Hardware Test

This can check whether the output and input interfaces of the controller are normally connected with external devices through IO test. Before I/O test, I/O test switch on, and then I/O test.

**Output Test:** under the IO test interface, start the output test, that is, after clicking the corresponding output port button, the color of the interface port will light up. The output state of the corresponding external connection should be valid. If it is invalid, it means the connection is abnormal.

**Input Test:** in the IO test interface, when the external input signal is valid, the corresponding input port color under the interface will light up to green. When the external input is valid, the interface has no response, indicating abnormal connection. Check the power supply input and wiring of the I/O Module.

#### 4.4.7 Display Style

1. Screen Save Time	You can set the time when the screen is off. Default: Never; Optional never /60 seconds /10 minutes /30 seconds /5 minutes /30 minutes
---------------------	---

2. MainPage Style	Optional: Easy Data Mode and Easy Test Mode. Default: Easy Data Mode.
3. Permission Auto Logout	Permission exit time setting. can choose 5 min, 10 min, 20 min,30 min.
4. Multiple User Login	Enable multi-user login function to set the number of users logged in
5. Number Of Users	The multi-user login switch is turned on to set the number of users logging in
6.Backlight Switch	The screen goes out when the backlight is turned on.
7.Backlight Length of Time	Turn on the backlight and set the backlight time. When the time is over ,the screen goes out .Click the screen to re-light up. Initial value: 15s; Range: 15~1800.(s)
8. Clear Sum	Clear accumulated rights. Initial value:Operator; Operator, Technician, Administrator.

#### 4.4.8 Tractor Parameters

When the scale structure includes net weigher and gross weigher scale, when selecting the Built-in Tractor machine from [Maintenance] - [Peripherals Select] - [Tractor], the traction machine parameters can be set in the system maintenance interface as follows:

<b>Slider</b>	Slider Mode	Step Motor
	Slider Backward Timeout	Default value: <b>5.0</b> ,Range: <b>0.0~99.9</b> . (Unit:s)
	Slider Pos. Signal Type	Default value: 0:ON:If in Closed; Range: <b>0: ON:If in Closed</b> (When the input is valid, it is considered accurate) ; <b>1: OFF:If in Closed</b> (When the input is invalid, it is considered accurate) .
	Power-ON Go 0 Pos. Freq	When the power is turned off and restarted, the motor returns to the origin at this frequency. Default value: <b>2000</b> , Range: <b>1~50000</b> . (Unit:Hz)
	Slider Forward Predelay	Default value: <b>0.0</b> ,Range: <b>0.0~99.9</b> . (Unit:s)
	Slider Backward Predelay	Default value: <b>0.0</b> , Range: <b>0.0~99.9</b> . (Unit:s)
	Slider Forward Frequency	Default value: <b>30000</b> ,Range: <b>1~50000</b> . (Unit:Hz)
	Slider Backward Frequency	Default value: <b>20000</b> , Range: <b>1~50000</b> . (Unit:Hz)
	Steps For Slider Forward	Default value: <b>12000</b> , Range: <b>1~60000</b> .
	Start Freq	Default value: <b>2000</b> , Range: <b>1~50000</b> (Unit:Hz) (This value cannot be greater than the clamping Arm

		lock frequency)
	ACC Time	Default value: <b>200</b> , Range: <b>0~9999</b> . (Unit:ms)
	DEC Time	Default value: <b>50</b> , Range: <b>0~9999</b> . (Unit:ms)
	DIR Signal Type	Motor rotation direction signal status. Default value: Forward When Signal Off; Optional: <b>Forward When Signal Off:</b> When the slider motor moves out, the motor rotation direction signal output is invalid. When the slider motor moves back, the motor rotation direction signal output is valid. <b>Forward When Signal On:</b> When the slider motor moves out, the motor rotation direction signal output is valid, and when the slider motor moves back, the motor rotation direction signal output is invalid.
	Slider DIR(OUT)	Quickly define input/output port.
	Backward Released Pos.(IN)	
	Slider Released PWM(OUT)	
<b>Clamping Arm Lock</b>	Clamping Arm Lock Mode	Step Motor
	UnClamping Arm Timeout	Default value: <b>3.0</b> ,Range: <b>0.0~99.9</b> . (Unit:s)
	Clamping Arm Pos. Signal Type	Default value: 0:ON:If in Closed; Optional: <b>0: ON:If in Closed</b> (When the input is valid, it is considered accurate) ; <b>1: OFF:If in Closed</b> (When the input is invalid, it is considered accurate) .
	Power-ON Go 0 Pos. Freq	When the power is turned off and restarted, the motor returns to the origin at this frequency. Default value: <b>2000</b> , Range: <b>1~50000</b> . (Unit:Hz)
	Clamping Arm Lock Predelay	Default value: <b>0.0</b> ,Range: <b>0.0~99.9</b> . (Unit:s)
	Clamping Arm Backward Delay	Default value: <b>0.0</b> ,Range: <b>0.0~99.9</b> . (Unit:s)
	Clamping Arm Lock Frequency	Default value: <b>30000</b> ,Range: <b>1~50000</b> . (Unit:Hz)
	UnClamping Arm Lock Frequency	Default value: <b>20000</b> ,Range: <b>1~50000</b> . (Unit:Hz)
	Steps For Clamping Arm Lock	Default value: <b>12000</b> ,Range: <b>1~60000</b> .
	Start Freq	Default value: <b>2000</b> ,Range: <b>1~50000</b> .(Unit:Hz) (This value cannot be greater than the clamping Arm lock frequency)

	ACC Time	Default value: <b>200</b> ,Range: <b>0~9999</b> (Unit:ms)
	DEC Time	Default value: <b>50</b> ,Range: <b>0~9999</b> . (Unit:ms)
	DIR Signal Type	Motor rotation direction signal status. Default value:Lock Bag When Signal Off; Optional: <b>Lock Bag When Signal Off:</b> When the clamping arm motor clamps the bag, the motor rotation direction signal output is invalid. When the clamping arm motor loosens the bag, the motor rotation direction signal output is valid. <b>Lock Bag When Signal On:</b> When the clamping arm motor clamps the bag, the motor rotation direction signal output is valid. When the clamping arm motor loosens the bag, the motor rotation direction signal output is invalid.
	Clamping Arm Lock DIR(OUT)	Quickly define input/output port.
	Clamping Arm Lock Pos.(IN)	
Clamping Arm Lock PWM(OUT)		
<b>Bracing Bags</b>	Stretching Bags Predelay	Default value: <b>0.0</b> ,Range: <b>0.0~99.9</b> . (Unit:s)
	UnStretching Bags Predelay	Default value: <b>0.0</b> , Range: <b>0.0~99.9</b> . (Unit:s)

#### 4.5 Peripheral parameters

Click the **【Peripherals】** menu bar in the main interface (Note: the corresponding peripheral switch in system maintenance parameters is turned on, and the corresponding peripheral parameters can only be seen)

##### 4.5.1 Patting Bag Parameters

Parameter	Description
1. Patting Mode	Select according to the pat bag mode of the system maintenance peripheral switch
2. Patting ON Timer	During the on-off cycle of the bag, the bag output valid time. Initial value: <b>0.5</b> ; Range: <b>0.0~99.9</b> . (unit s)
3. Patting OFF Timer	In the on-off cycle of the bag, the bag output invalid time. Initial value: <b>0.5</b> ; Range : <b>0.0~99.9</b> . (unit s)
4. Patting PreDelay Timer	After the bag is started, the bag output is valid after this delay time. Initial value: <b>0.5</b> ; Range : <b>0.0~99.9</b> . (units )
5. Patting Times(HOLD)	After the fixed value, the number of times the bag is set, the number of times the bag is taken. Initial value: <b>4</b> ; Range: <b>0~99</b> .
6. Extra Patting Timer	Generally used in the anchor bag function.

	<p>(Note: The patting mode is ALL Time and the parameters are only visible)</p> <p>After all the bags are finished, the additional bag output is added once, and the effective time is set to the time. The invalid time is "Patting OFF Timer".</p> <p>Initial value: <b>0.0</b>. Range: <b>0.0~99.9</b>. (units)</p> <p>(Note: the time when the unlock bag is delayed is not changed, or the "lead bag delay" time is started after all the original bag output ends effectively, that is, the effective time of the extra bag output is started after the bag output valid time is over. To achieve the abutment function, the time and the "unlock bag delay" time should be set appropriately, but the time setting should generally be greater than the "unlock bag delay", that is, the bag should be unlocked first, then the bag mechanism will rise again).</p>
7. Start-Up Weight 1	<p>Under gross weigher, jumbo bag, valve scale mode are valid, choose Filling medium pat bag mode, current weight must <math>\geq</math> pat bag start up weight, starts pat bag.</p> <p>Initial value: <b>0</b>; Range: <b>0 ~ Maximum range</b>.</p>
8. Start-Up Weight 2	<p>The current weight must be greater than or equal to the starting weight of the racket bag 2 to start the racket bag.</p> <p>Initial value: <b>0</b>; Range: <b>0~ maximum range</b></p>
9. Start-Up Weight 3	<p>The current weight must be greater than or equal to the starting weight of the racket bag 3 to start the racket bag.</p> <p>Initial value: <b>0</b>; Range: <b>0~ maximum range</b>.</p>
10. Patting Times(Filling) 1	<p>Setting parameter for the number of patting bags in filling, if set to 0, no patting bags. Note: when the filling process enters the fine filling, force the end of the filling bag, no matter whether the filling bag is completed or not. (After entering the small throw, do not shoot the bag in the middle of filling)</p> <p>The number of raps corresponding to the starting weight of the bag 1</p> <p>Initial value: <b>0</b>; Range: <b>0~99</b>.</p>
11. Patting Times(Filling) 2	<p>The number of raps corresponding to the starting weight of the bag 2</p> <p>Initial value: <b>0</b>; Range: <b>0~99</b>.</p>
12. Patting Times(Filling) 3	<p>The number of raps corresponding to the starting weight of the bag 3</p> <p>Initial value: <b>0</b>; Range: <b>0~99</b>.</p>
13. Patting output interface	<p>This can be used to quickly define the output of the patting switching I/O module.</p>

#### 4.5.2 Sewing Parameters

1. Sewing Switch	<p>The peripheral switch is set to "on" to turn on the function of the bagging machine</p>
2. Sewing Start Delay Timer	<p>After the sewing machine start ON/OFF is activated, the sewing machine delay time is started.</p> <p>Initial value: <b>0.5</b>. Range: <b>0.0~99.9</b>. (unit s)</p>

3. Sewing ON Timer	After the delay time has elapsed, the sewing machine output is started and the sewing machine output time is continuously output . Initial value: <b>4.0</b> . Range: <b>0.0~99.9</b> . (unit s)
4. Sewing Stop Delay Timer	After the sewing ON Timer of the sewing machine is reached, execute this time, and when this time is reached, the sewing machine will stop working. Initial value: 0.5.Range: 0.1~99.9.(unit s)
5.Sewing Debounce Timer	Prevent the abnormal operation of the sewing caused by the photoelectric jitter of the sewing starting.During the de-shaking time, the photoelectric jitter of the baling, but the output of the baling is still valid at this time. Initial value: 0.3.Range: 0.0~99.9.(unit s)
6. Cutter PreDelay Timer	After the sewing ON Timer of the sewing machine, start the Cutter PreDelay Timer and continue the cutting machine with the delay time.Initial value: 0.5.Range: 0.0~99.9.(unit s)
7. String Cut ON Timer	After the start up of the cutter, start the output of the cutter and continue the output time of the cutter. Initial value: 0.5.Range: 0.0~99.9.(unit s)
8. IO function define	This can be used to quickly define the input port of the start and emergency stop of the bagging machine, and the output port of the bagging machine and the thread cutting machine.

#### 4.5.3 DISC Shaking Parameters

1.DISC Shaking Switch	The peripheral switch is set to "Individual Shaking or DISC Shaking" to open the Discharge patting function
2. DISC Shaking Trigger Time	When the fixed value hold time is, the period from the start of output discharge signal to the start of discharge delay after discharge is completed is the effective discharge time.When the unloading duration exceeds this time, it is considered abnormal and the unloading vibration action is started Initial value: <b>2.0</b> ; range <b>0.0~9.9</b> . (Unit s)
3. DISC Shaking ON Timer	Initial value: <b>0.5</b> ; range <b>0.0~9.9</b> (Unit s)
4. DISC Shaking OFF Timer	Initial value: <b>0.5</b> ; range <b>0.0~9.9</b> (Unit s)
5. DISC Shaking Times	Initial value: <b>10</b> ; range <b>0~99</b>
6. DISC Shaking(OUT)	This can be used to quickly define the discharge vibration output port.

#### 4.5.4 Conveyor Parameters

1. Conveyor Control	When the peripheral switch selects the 1 Conveyor /2 Conveyor /3 Conveyor, the output function of the conveyor is turned on.
2. Conveyor1 Start Delay Timer	After the delay of the unlock bag, the controller judges that the conveyor is started. Initial value: 0.5 ; range: 0~99.9 . (unit s )
3. Conveyor1 Running	Conveyor runtime setting.



Timer	Initial value: 4.0 ; range: 0~99.9 . (unit s )
4. Conveyor 2&3 Max Run Timer	Conveyor 2/3 runtime setting. (Note: In the jumbo bag and binyes Multi-scale mode, the parameters of 2 conveyor or 3 conveyor can only be seen when the conveyor level is turned on) Initial value: 30.0; range: 0~99.9. (unit s)
5. IO Function Select	Through this, the I/O module related to conveyor can be quickly defined, including Conveyor 1 Manual Forward Run(IN), Conveyor 1 Manual Reverse(IN), Conveyor 1 Run (OUT), Conveyor 1 Reverse Start(OUT),Limit Position Of Conveyor 2(IN),Conveyor 2 Run(OUT).

#### 4.5.5 Coding Parameters

1. Coding Device ON/OFF	On/off optional; set to "on", the controller has a code output function; Initial value : off.
2. Coding Start Delay Timer	The bag clamping is completed, and after this delay, the coding output is valid . Initial value: 0 .5 ; Range: 0.0~99.9 . (units )
3. Coding Timer	The effective time of coding; Initial value: 0 .5 ; Range: 0.0~99.9 . (units )
4.Disable Fill/Discharge When Coding	On/Off is optional; set to "On", it is not allowed to start filling (no bucket mode) output or unloading (with bucket mode) output during coding . Initial value : off.

#### 4.5.6 Aux. Pulse Ctrl Parameters

Auxiliary Pulse Switch	The peripheral ON/OFF is set to "on" to enable the auxiliary pulse function
Aux. Pulse Control	Auxiliary pulse mode 1~4 can be selected according to requirements 0: Pulse mode;1: Always ON. Initial value: 0: ON/OFF Pulse mode.
Aux. Pulse 1 Execute Time	Auxiliary Pulse 1 Execute Total Timer. If 0, keeps running. Initial value : 0 ; range : 0.0~999.9 .(unit s )
Aux. Pulse 1 ON Time	Initial value : 10.0 ; range : 0.0~999.9 .(unit s )
Aux. Pulse 1 OFF Time	Initial value : 10.0 ; range : 0.0~999.9 .(unit s )
Aux. Pulse 2 Execute Time	Auxiliary Pulse 2 Execute Total Timer. If 0, keeps running. Initial value : 0 ; range : 0.0~999.9 .(unit s )
Aux. Pulse 2 ON Time	Initial value : 10.0 ; range : 0.0~999.9 .(unit s )
Aux. Pulse 2 OFF Time	Initial value : 10.0 ; range : 0.0~999.9 .(unit s )
Aux. Pulse 3 Execute Time	Auxiliary Pulse 3 Execute Total Timer. If 0, keeps running. Initial value : 0 ; range : 0.0~999.9 .(unit: min )

Aux. Pulse 3 ON Time	Initial value : <b>10.0</b> ; range : <b>0.0~999.9</b> .(unit: min )
Aux. Pulse 3 OFF Time	Initial value : <b>10.0</b> ; range : <b>0.0~999.9</b> .(unit: min )
Aux. Pulse 4 Execute Time	Auxiliary Pulse 4 Execute Total Timer. If 0, keeps running. Initial value : <b>0</b> ; range : <b>0.0~999.9</b> .(unit min )
Aux. Pulse 4 ON Time	Initial value : <b>10.0</b> ; range : <b>0.0~999.9</b> .(unit: min )
Aux. Pulse 4 OFF Time	Initial value : <b>10.0</b> ; range : <b>0.0~999.9</b> .(unit: min )
IO Function Select	This allows for quick definition of the switch values for the input and output ports of auxiliary pulses 1-4.

#### 4.5.7 Fill& DISC OverTime Parameters

Fill& DISC OverTime Switch	Add and discharge timeout judgment ON/OFF. After the opening , the loading and unloading timeout judgment is performed in the running state . Initial value : off .
Co-Fill OverTime	In the running state, after the coarse output exceeds the time, the output timeout alarm is issued and the machine stops. Initial value : <b>5.0</b> ; range <b>0.0~99.9</b> . (unit:s )
Me-Fill OverTime	In the running state, after the output is over this time, the output timeout alarm is issued and the machine stops. Initial value : <b>5.0</b> ; range <b>0.0~99.9</b> . (unit:s )
Fi-Fill OverTime	In the running state, after the fine output exceeds the time, the output timeout alarm is issued and the machine stops. Initial value : <b>5.0</b> ; range : <b>0.0~99.9</b> .(unit:s )
DISC OverTime	In the running state, after the discharge output exceeds this time, the output timeout alarm and stop. Initial value : <b>5.0</b> ; range : <b>0.0~99.9</b> .(unit:s )

## 4.6 Motor parameter

When the scale structure is Net Weigher, Gross Weigher, Jumbo bag and Valve Scale structure, the "Filling Gate mode", "Clamper Mode " and "DISC Gate Mode" of the system maintenance parameter scale property are set to the motor mode, and the following parameters can be seen.

- ◆ Enter the interface of motor parameters from [Menu] - [Motor].
- ◆ The unit number on the right side can be switched.

### 4.6.1 Filler

Parameter	Description
<b>1. Filling Gate Mode</b>	Initial value: Air Drived; 0:Air Drived, 1: Step Motor, 2: Motor Drived. (Note: Select the corresponding filling motor mode and set the corresponding parameters).
<b>2. Filler Gate Closed Pos.Signal</b>	ON:If Closed (If input is valid, gate closed ready).

		OFF: If Closed(If input is invalid, gate closed ready).
<b>3. Motor Linker</b>		Set receipt ID relate to Motor ID
<b>4. Filler Gate Close Timeout</b>		Default: <b>4.0</b> , Range: <b>0.0~99.9</b> (Unit: <b>s</b> )
<b>5. Step Motor parameter setting</b>	<b>a. Filler Motor frequency</b>	Default: <b>12000</b> , Range: <b>1~50000</b> (Unit: <b>Hz</b> )
	<b>b. Motor Steps For Fi-Fill</b>	Default: <b>1800</b> , Range: <b>1~60000</b>
	<b>c. Motor Steps For Me-Fill</b>	Default: <b>4300</b> , Range: <b>1~60000</b>
	<b>d. Motor Steps For Co-Fill</b>	Default: <b>7750</b> , Range: <b>1~60000</b>
	<b>e. Manual Fi-Fill/ Manual Me-Fill/ Manual Co-Fill</b>	Test shortcut key, used to check the device opening status, to quickly adjust the pulse number
	<b>f. Start Freq</b>	Filling motor Start Frequency. Default: <b>2000</b> Range: <b>1~50000</b> . (Unit: <b>Hz</b> ) (This value cannot bigger than the filling motor frequency)
	<b>g. ACC Time</b>	Filling motor ACC Time Default: <b>200</b> , Range: <b>0~9999</b> (Unit <b>ms</b> )
	<b>h. DEC Time</b>	Filling motor DEC Time Default: <b>50</b> , Range: <b>0~9999</b> . (Unit <b>ms</b> )
	<b>i. IO Function Select</b>	Options: a) DIR Signal Type: <b>0 Gate Open When Signal Off:</b> when the filling door opening action, the output of the rotation direction signal of the filling stepper motor is invalid, and the output of the direction signal is effective when the closing action; <b>1 Gate Open When Signal On:</b> when the filling step motor is opening the door, the output of the rotation direction signal of the filling step motor is effective, and the output of the direction signal of the closing action is invalid. b) Quickly define IO Port, Filler Gate Closed Pos.(IN), Filler Gate DIR(OUT), Filler Gate PWM(OUT)
	<b>j. Power-ON Go 0 Pos. Freq</b>	When the power is off and restarted, the filling motor returns to the origin with this frequency. Initial value: <b>2000</b> , Range: <b>0~50000</b> . (Unit Hz)
<b>k. Motor Steps For Closed</b>	Default value: <b>100</b> , range: <b>1-60000</b> (This parameter is only visible when the No Position Signal For Fill Gate and the signal is open in the maintenance attribute parameter of the scale structure.) Note: For example, if the instrument opens the door with 10000 pulses, closing the door means (10000+feeding closing pulses). When closing the door, output more pulses to ensure that the door is closed properly.	
<b>6. Motor Drived parameter setting</b>	<b>a. Fi-Fi Gate Time</b>	The time required to open the filling door to the Fi-F position. Initial value: <b>0.2</b> , Range: <b>0~99.99</b> (Unit <b>s</b> )
	<b>b Me-Fi Gate Time</b>	The time required to open the filling door to the Me-F

		position. Default: <b>0.4</b> ,Range: <b>0~99.99</b> (Unit s)
	c.Co-Fi Gate Time	The time required to open the filling door to the Fa-F position. Default: <b>0.8</b> ,Range: <b>0~99.99</b> (Unit s)
	d. Manual Fi-Fill/ Manual Me-Fill/ Manual Co-Fill	Test shortcut key, used to check the state of the equipment, to quickly adjust the motor coarse, fine time.
	e. Filling Gate Closed Pos.(IN)	Quickly set the input/output port of filling related I/O module
	f. Filling Open(OUT)	
	g. Filling Close(OUT)	

#### 4.6.2 Clamper

1. Clamper Mode	Air Driven,Step Motor,MotorDrive Dual-Limit, MotorDrive Single-Limit (Note: Select the corresponding bag clamping mode and set the corresponding parameters)	
2. Clamper Pos. Signal Type	Clamper Pos. Signal Type . ON:If Closed: If input is valid, gate closed ready. OFF:If Closed If input is invalid, gate closed ready.	
3. Clamper Open Timeout	Default: <b>3.0</b> , Range: <b>0.0~99.9</b> (Unit s) ; It can be set in both Step Motor and MotorDrive Dual-Limit mode.	
4. Clamper Close Timeout	Default: <b>3.0</b> , Range: <b>0.0~99.9</b> (Unit s) ; It can be set in both MotorDrive Dual-Limit and MotorDrive Single-Limit mode.	
5.Clamper Button	Quick button for bag clamping, used to check the condition of the bag clamping equipment.	
6. Step motor parameter	a. Clamper Close Frequency	Default: <b>30000</b> ,Range: <b>1~50000</b> (Unit:Hz)
	b. Clamper Open Frequency	Default: <b>20000</b> ,Range: <b>1~50000</b> (Unit Hz)
	c. Steps For Clamper Close	Default: <b>12000</b> ,Range: <b>1~60000</b>
	d. Start Freq	Default: <b>2000</b> ,Range: <b>1~50000</b> (Unit Hz) (this value can't bigger than Clamper Close Frequency)
	e. ACC Time	Default: <b>200</b> , Range: <b>0.0~9999</b> (Unit ms)
	f. DEC Time	Default: <b>50</b> , Range: <b>0.0~9999</b> (Unit ms)
	g.IO Function Select	Optional A) DIR Signal Type: <b>0 Lock Bag When Signal Off:</b> when the bag unlockning mechanism clamps the bag, the rotation direction signal output of the stepping motor of the

		<p>bag unlockning mechanism is invalid, but the direction signal output is effective when the bag unlockning mechanism clamps the bag;</p> <p><b>1 Lock Bag When Signal On:</b> when the bag is clamped unlock, the rotation direction signal output of the stepper motor of the bag is effective, but when the bag is clamped unlock, the direction signal output is invalid.</p> <p>b) Quickly define the switching quantity of input /output port, Bag Release Pos.(IN),Clamper Open DIR(OUT),Bag Released PWM(OUT)</p>
	h. Power-ON Go 0 Pos. Freq	<p>When the power is cut off and restarted, the clutch motor returns to the origin at this frequency.</p> <p>Initial value: <b>2000</b>, range: <b>0~50000</b>. (Unit Hz)</p>
	i.Steps For Clamper Open	<p>Default value: <b>100</b>, range: <b>1-60000</b></p> <p>( This parameter is only visible when the No Position Signal For Clamper and the signal is open in the maintenance attribute parameter of the scale structure. )</p> <p>Note: For example, if the instrument loosens the bag by 10000 pulses, the clamping bag is (10000+number of loosening bag pulses). When loosening the bag, output more pulses to ensure that the bag is in place.</p>
7. MotorDrive Dual-Limit parameter	a. Bag Locked Pos.(IN)	<p>Quick setting of motor double limit lock unlock bag related switch input and output ports.</p>
	b. Bag Released Pos.(IN)	
	c. Lock Bag(OUT)	
	d. Released Bag (OUT)	
8. MotorDrive Single-Limit Parameter	a. Bag Release Time	<p>Normal motor release bag valid time</p> <p>Default: <b>0.5</b>, range: <b>0~99.99</b> (Units)</p>
	b. Bag Locked Pos.(IN)	<p>Quick setting of motor single limit clutch bag related switch input and output ports.</p>
	c. Lock Bag(OUT)	
	d. Released Bag (OUT)	

#### 4.6.3 DISC(Parameters can be set in net weigher mode)

1.DISC Gate Mode	<p>Air Driven,Step Motor, MotorDrive Dual-Limit, MotorDrive Single-Limit,Normal Motor Rotating</p> <p>(Note: Select the corresponding discharge motor mode and set the corresponding parameters)</p>
2. DISC Gate Close Timeout	<p>Default: <b>3.0</b> range: <b>0.0~99.9</b> (Unit s)</p> <p>(The DISC motor mode is MotorDrive Dual-Limit, MotorDrive Single-Limit,Normal Motor Rotating, the parameters are visible.)</p>

3. DISC Gate Pos. Signal Type		<b>0 ON:If Closed:</b> (when the input is valid, the door is considered to be in place). <b>1 OFF:If Closed:</b> (when the input is invalid, the door is considered to be in place).
4.Manual DISC Button		Manual Discharge shortcut button.
5.Step motor DISC parameter setting	a. DISC Motor Open Frequency	Default: <b>30000</b> , range: <b>1~50000</b> (Unit Hz)
	b. DISC Motor Close Frequency	Default: <b>20000</b> , range: <b>1~50000</b> (Unit Hz)
	c. Discharge Steps	Default: <b>12000</b> , range: <b>1~60000</b>
	d. Start Freq	Default: <b>2000</b> ,range: <b>1~50000</b> (Unit Hz) (this value can't bigger than discharge frequency)
	e. ACC Time	Default: <b>200</b> , range: <b>0.0~9999</b> (Unit ms)
	f. DEC Time	Default: <b>50</b> , range: <b>0.0~9999</b> (Unit ms)
	g.IO function Select	Optional a) DIR Signal Type: <b>0Gate Open When Signal Off:</b> when discharge mechanism opens the door, the direction signal output of discharge stepper motor is invalid, and the direction signal output is effective when closing the door; <b>1Gate Open When Signal On:</b> when discharge mechanism opens the door, the rotation direction signal output of discharge stepper motor is effective, and the direction signal output is invalid when closing the door. b) Quickly define the switching quantity of input /output port,DISC Gate Closed Pos.(IN), DISC Gate DIR (OUT) and DISC Gate PWM (OUT).
	h. Power-ON Go 0 Pos. Freq	When the power is cut off and restarted, the clutch motor returns to the origin at this frequency. Initial value: <b>2000</b> , range: <b>0~50000</b> . (Unit Hz)
	i.Discharge Steps For Closed	Default value: <b>100</b> , range: <b>1-60000</b> (This parameter is only visible when the No Position Signal For DISC Gate and the signal is open in the maintenance attribute parameter of the scale structure.) Note: For example, if the instrument unloads and opens the door with 10000 pulses, closing the door will result in (10000+unloading and closing pulses). During unloading, output more pulses to ensure that the unloading and closing doors are in place.
6. MotorDrive Dual-Limit parameter setting	a. DISC Gate Close Timeout	Default: <b>3.0</b> ,range: <b>0.0~99.9</b> (Unit s)
	b. DISC Gate Opemd Pos.(IN)	Quick setting of motor double limit discharge related switch input and output ports.
	c. DISC Gate Closed Pos.(IN)	

	d. DISC Motor Open (OUT)	
	e. DISC Motor Closed (OUT)	
7. MotorDrive Single-Limit parameter setting	a. DISC Gate Open Timer	Motor opening signal output time Default: 1.00,range: 0.00~99.99 (Unit s)
	b. DISC Gate Closed Pos.(IN)	Quick setting of motor single limit discharge related switch input and output ports
	c. DISC Motor Open (OUT)	
	d. DISC Motor Closed (OUT)	
8. Normal Motor Rotating parameter setting	a. DISC Gate Open Timer	Motor opening signal output time Default: 1.00,range: 0.00~99.99 (Unit s)
	b. DISC Gate Closed Pos.(IN)	Quickly set the input and output ports of the I/O module related to discharging in one direction rotation of the motor.
	c. DISC Motor Closed (OUT)	

#### 4.7 Statistics

In the main interface, click **【Statistic】** to enter the interface.Under the **【Statistic】** parameter, the user can view the total accumulation/batch, recipe accumulation, user accumulation, history record and carry out clearing, printing and other operations.

- ◆ Under the **【ACUM/Batch】** interface, you can view the total ACUM and Batch and set the batch.If the serial port is set to print, click **【Data Edit】** to print the total ACUM and clear the total ACUM and the batch info. .
- ◆ In total accumulated with batch interface can set **【Batch set】** , such as a complete set of batch, controller in the main interface box prompts "Batch Completed" alarm, wait for the user processing, when the "clear alarm" input signal effectively, or "Clear Alarm" button, controller will clear the alarm, it can remove or input stop back to stop state can clear alarm.
- ◆ Under “Recipe ACUM ”, check the cumulative times and weight of each recipe ID. Click the right side of the interface to switch recipe ID 1-10 and 11-20. Click "Data Edit" to clear all recipe ACUM data, print a all recipe ACUM data , print the present recipe ACUM data and select recipe ACUM data to print.
- ◆ Click the formula accumulation to be deleted in the “recipe ACUM" interface to delete the selected recipe ACUM data content.
- ◆ Under **【User ACUM】** , check the ACUM times and ACUM weight. Click **【Data Edit】** to clear all user ACUM data, print all user ACUM data, print present user ACUM data, select user ACUM data printing.
- ◆ Click the user accumulation to be deleted in the **【User ACUM】** interface to delete the selected user accumulation content.
- ◆ In the **【History Data】** interface, you can view the history. Click **【Data Edit】** to export the history through the U disk or clear the historical data.

Note: if working in combination mode, the number of batches completed is increased by 1.The batch PCS and the accumulated PCS are power-off and saved.

## 4.8 I/O Function

The **GM9907** provides **12** inputs and **16** output interfaces to interface the controller with external devices.

The input and output factory definition contents are as follows output **1 - 16** corresponds to the controller **OUT1 ~ OUT16** interface, input **1 - 12** corresponds to the controller **IN1 ~ 12** interface).

There are net weigher scales default definition:

Output		Input	
OUT01	<b>O1</b> Running	IN01	<b>I1</b> Start
OUT02	<b>O2</b> Stopped	IN02	<b>I2</b> E-Stop
OUT03	<b>O3</b> Co-Fill	IN03	<b>I3</b> Stop
OUT04	<b>O4</b> Me-Fill	IN04	<b>I5</b> ZERO
OUT05	<b>O5</b> Fi-Fill	IN05	<b>I6</b> Clear Alarm
OUT06	<b>O6</b> Lock Bag	IN06	<b>I8</b> Clear Total ACUM
OUT07	<b>O7</b> HOLD	IN07	<b>I7</b> Bag Lock/Unlock Request
OUT08	<b>O8</b> Ready	IN08	<b>I9</b> Manual DISC(button)
OUT09	<b>O9</b> DISC	IN09	<b>I10</b> Manual Fi-Fill(button)
OUT10	<b>O10</b> (-NZ-)	IN10	<b>I11</b> Manual Co-Fill(button)
OUT11	<b>O11</b> Patting Bag	IN11	<b>I13</b> Change Recipe
OUT12(PWM)	<b>O13</b> FILL Supplement	IN12	<b>I12</b> Empty Material
OUT13(PWM)	<b>O14</b> Supplement Empty	Note: In interlock mode. IN12 is the interlock input. OUT16 is the interlock output.	
OUT14(PWM)	<b>O15</b> Alarm		
OUT15(PWM)	<b>O17</b> Batch Complete		
OUT16(PWM)	<b>O16</b> Over/Under		

Gross weigher scale default definition:

Output		Input	
OUT01	<b>O1</b> Running	IN01	<b>I1</b> Start
OUT02	<b>O2</b> Stopped	IN02	<b>I2</b> E-Stop
OUT03	<b>O3</b> Co-Fill	IN03	<b>I3</b> Stop
OUT04	<b>O4</b> Me-Fill	IN04	<b>I4</b> Pause
OUT05	<b>O5</b> Fi-Fill	IN05	<b>I5</b> ZERO
OUT06	<b>O6</b> Lock Bag	IN06	<b>I6</b> Clear Alarm
OUT07	<b>O7</b> HOLD	IN07	<b>I7</b> BagLock/Unlock Request
OUT08	<b>O10</b> (-NZ-)	IN08	<b>I8</b> Clear Total ACUM
OUT09	<b>O11</b> Patting Bag	IN09	<b>I10</b> Manual Fi-Fill(button)
OUT10	<b>O15</b> Alarm	IN10	<b>I11</b> Manual Co-Fill(button)
OUT11	<b>O13</b> FILL Supplement	IN11	<b>I13</b> Change Recipe
OUT12(PWM)	<b>O27</b> Bag Lock	IN12	<b>I0</b> None
OUT13(PWM)	<b>O14</b> Supplement Empty	Note: In interlock mode. IN12 is interlock input .	



OUT14(PWM)	<b>O17</b> Batch Complete	OUT12 is changed to Supplement Empty. OUT13 is changed to Batch Completed. OUT14 is changed to the sewing. OUT 15 is changed to conveyor1. OUT 16 is changed to interlock output.
OUT15(PWM)	<b>O16</b> Over/Under	
OUT16(PWM)	<b>O44</b> Sewing	

Jumbo Bag default definition:

Output		Input	
OUT01	<b>O1</b> Running	IN01	<b>I1</b> Start
OUT02	<b>O2</b> Stopped	IN02	<b>I2</b> E-Stop
OUT03	<b>O3</b> Co-Fill	IN03	<b>I3</b> Stop
OUT04	<b>O4</b> Me-Fill	IN04	<b>I4</b> Pause
OUT05	<b>O5</b> Fi-Fill	IN05	<b>I5</b> ZERO
OUT06	<b>O6</b> Lock Bag	IN06	<b>I6</b> Clear Alarm
OUT07	<b>O31</b> Hanging Lift Bag	IN07	<b>I8</b> Clear Total ACUM
OUT08	<b>O34</b> Holder Up	IN08	<b>I7</b> BagLock/Unlock Request
OUT09	<b>O7</b> HOLD	IN09	<b>I32</b> Hanging Lift Bag
OUT10	<b>O10</b> (-NZ-)	IN10	<b>I3</b> Manual Hanger Up/Down
OUT11	<b>O33</b> Return Valve	IN11	<b>I10</b> Manual Fi-Fill(button)
OUT12(PWM)	<b>O32</b> AirBlow	IN12	<b>I11</b> Manual Co-Fill(button)
OUT13(PWM)	<b>O15</b> Alarm		
OUT14(PWM)	<b>O17</b> BatchComplete		
OUT15(PWM)	<b>O0</b> None		
OUT16(PWM)	<b>O0</b> None		

Valve scale default defined:

Output		Input	
OUT01	<b>O1</b> Running	IN01	<b>I1</b> Start
OUT02	<b>O2</b> Stopped	IN02	<b>I2</b> E-Stop
OUT03	<b>O3</b> Co-Fill	IN03	<b>I3</b> Stop
OUT04	<b>O4</b> Me-Fill	IN04	<b>I4</b> Pause
OUT05	<b>O5</b> Fi-Fill	IN05	<b>I5</b> ZERO
OUT06	<b>O6</b> Lock Bag	IN06	<b>I6</b> Clear Alarm
OUT07	<b>O7</b> HOLD	IN07	<b>I8</b> Clear Total ACUM
OUT08	<b>O17</b> Batch Complete	IN08	<b>I7</b> Bag Lock/Unlock Request
OUT09	<b>O10</b> (-NZ-)	IN09	<b>I10</b> Manual Fi-Fill(button)
OUT10	<b>O11</b> Patting Bag	IN10	<b>I11</b> Manual Co-Fill(button)
OUT11	<b>O13</b> FILL Supplement	IN11	<b>I13</b> Change Recipe
OUT12(PWM)	<b>O15</b> Alarm	IN12	<b>I0</b> None
OUT13(PWM)	<b>O16</b> Over/Under		

OUT14(PWM)	<b>O30</b> Pushing Bag Signal
OUT15(PWM)	<b>O29</b> Lifting Bag Signal
OUT16(PWM)	<b>O42</b> Conveyor 1

PLC mode default definition:

Output		Input	
OUT01	<b>O3</b> Co-Fill	IN01	<b>I5</b> ZERO
OUT02	<b>O4</b> Me-Fill	IN02	<b>I6</b> Clear Alarm
OUT03	<b>O5</b> Fi-Fill	IN03	None
OUT04	<b>O38</b> Over (PLC )	IN04	None
OUT05	<b>O39</b> Under(PLC)	IN05	None
OUT06	<b>O49</b> Upper Limit(PLC)	IN06	None
OUT07	<b>O41</b> Lower Limit(PLC)	IN07	None
OUT08	None	IN08	None
OUT09	None	IN09	None
OUT10	None	IN10	None
OUT11	None	IN11	None
OUT12(PWM)	None	IN12	None
OUT13(PWM)	None		
OUT14(PWM)	None		
OUT15(PWM)	None		
OUT16(PWM)	None		

#### 4.8.1 Output, input port definition

Output port, input port content can be defined according to the actual application. Modify the definition of input and output I/O module parameters through the menu interface I/O module parameters. Each I/O module corresponds to a code, as follows:

I/O module content description

Output		
Code	Content	Description
<b>O0</b>	None	If the port number is defined as <b>0</b> , this output port is undefined.
<b>O1</b>	Running	When the controller is in the running state, the output port signal is valid.
<b>O2</b>	Stopper	When the controller is in the stop state, the output port signal is valid.
<b>O3</b>	Co-Fill	Used to control the large discharge port of the filling mechanism. During the filling process, when the current weight is less than the target value -coarseer advance amount, the output port signal is defined as valid.
<b>O4</b>	Me-Fill	Used to control the middle discharge port of the filling mechanism. During the addition, the current weight is less than the target value - added inadvice during the definition output signal is active.

<b>O5</b>	Fi-Fill	Used to control the small discharge port of the filling mechanism. During the filling process, when the current weight is less than the target value -fall difference, the output port signal is defined as valid.
<b>O6</b>	Lock Bag	It is used to control the pocket mechanism, and the signal effectively realizes the pocket; the signal is invalid, that is, the unlock bag.
<b>O7</b>	HOLD	Used to indicate the end of the filling process. The output port signal is valid before the end of the fine addition to the discharge (with bucket) or the bag (no bucket).
<b>O8</b>	Ready	After the setting is completed, the output port signal is valid.
<b>O9</b>	DISC	A discharge door for controlling the measuring bucket. The defined output port signal is valid when the discharge is started, so that the material is discharged from the measuring bucket into the package.
<b>O10</b>	(-NZ-)	When the current weight of the scale is less than the set near zero value, the output port signal is valid.
<b>O11</b>	Patting Bag	Used to control the bag making machine. A pulse signal with a controlled pulse width and number of times.
<b>O12</b>	Cutting Gate Open	This output is valid during the fill and is not valid during the non-fill period.
<b>O13</b>	FILL Supplement	The filling mechanism for controlling the front end of the bagging scale, when the filling hopper lower level input (the lower material level input is defined) is invalid, the output is valid; when the filling hopper upper material level (the loading level input is defined) is valid, The controller invalidates this output.
<b>O14</b>	Supplement Empty	When the blanking input is defined and the input is invalid, the output is valid. When the hopper lowering level (the lowering input is defined) is valid, the controller invalidates the output.
<b>O15</b>	Alarm	When the controller has an out-of-tolerance, batch number, etc. alarm, the output port signal is valid.
<b>O16</b>	Over/Under	When the tolerance or undershoot is exceeded, the output signal is defined as valid.
<b>O17</b>	Batch Complete	When the set number of batches is completed, the output port signal is valid.
<b>O18</b>	Interlock Output	Used in the double scale mode, connected to the ON/OFF "Double scale interlock input" of another controller.
<b>O19</b>	Filler Gate PWM	When the filling mode is set to stepper motor mode to control the filling door ON/OFF: This signal is used as a pulse signal output to the filling stepper motor driver to control the motor rotation. <b>Note: This function can only be defined on one of the ports of OUT12~16 .</b>
<b>O20</b>	Filler Gate DIR	When the filling mode is set to stepper motor mode to control the filling door ON/OFF: This signal is used as the motor rotation direction signal output to the filling stepping motor driver to control the motor to reverse. <b>Note: This function can only be defined on one output port. There can be no multiple output ports to define this function. And can only be defined to one of the ports OUT1~11 .</b>

<b>O21</b>	Clamper PWM	When the bag mode is set to the stepping motor mode control lock unlock bag: This signal is used as the output pulse signal to the pinch stepper motor driver to control the motor rotation. <b>Note: This function can only be defined on one of the ports of OUT12~16 .</b>
<b>O22</b>	Clamper DIR	When the bag mode is set to the stepping motor mode control lock unlock bag: This signal is used as the motor rotation direction signal output to the pinch bag stepping motor driver to control the motor to reverse. (No bucket mode is valid) <b>Note: This function can only be defined on one output port. There can be no multiple output ports to define this function. And can only be defined to one of the ports OUT1~11 .</b>
<b>O23</b>	DISC Gate PWM	When the unloading mode is set to stepper motor mode to control unloading: this signal is used as a pulse signal output to the discharge stepper motor driver to control the motor rotation. <b>Note: This function can only be defined on one of the ports of OUT12~16 .</b>
<b>O24</b>	DISC DIR	When the unloading mode is set to stepper motor mode to control unloading: this signal is used as the motor rotation direction signal output to the discharge stepper motor driver to control the motor to reverse. <b>Note: This function can only be defined on one output port. There can be no multiple output ports to define this function. And can only be defined to one of the ports OUT1~11 .</b>
<b>O25</b>	Filler Open	When the filling mode is set to the normal motor mode to control the filling door ON/OFF: the large discharging port for controlling the weighing mechanism is opened. This signal is active at the beginning of the filling process and the effective time is set in the motor parameters.
<b>O26</b>	Filler Close	When the filling mode is set to the normal motor mode to control the filling door ON/OFF: it is used to control the action of closing the filling port of the filling mechanism. The signals are valid at the time of coarse addition, medium addition and fine addition respectively. The effective time is based on the time parameter set in the motor parameters. It is decided that the signal is valid at the end of the fill until it becomes invalid when the fill limit is valid.
<b>O27</b>	Bag Unlock	When the bag mode is set to the ordinary motor control lock unlock bag: it is used to control the unlock bag. When the signal is valid, the motor is driven to perform the unlock bag action. When the signal is invalid, the unlock bag action stops.
<b>O28</b>	DISC Gate Close	When the unloading mode is set to normal motor forward and reverse control discharge, it is used to control the closing action of the controlling bucket discharge door. When the signal is valid, the motor is driven to open and close the door. When the signal is invalid, the door closing action stops.
<b>O29</b>	Lifting Bag	It is used to control the bag-making mechanism, and this signal effectively realizes the bag-lifting action .
<b>O30</b>	Pushing Bag	It is used to control the push bag mechanism, and the signal effectively realizes the push bag action.
<b>O31</b>	Hanging Lift Bag	It is used to control the bag mechanism, and the signal effectively realizes the hanging bag; the signal is invalid and the hook is unlock.

<b>O32</b>	AirBlow	For controlling the operation of the blowing means,at the end of the controlling bracket upward, the signal is valid.
<b>O33</b>	Return Valve	Return valve for controlling the run, at the end of blowing, the signal is valid.
<b>O34</b>	Holder Up	Used to control the upstream of the controlling bracket. This signal is valid until the upper limit is valid if both the bag and the bag have been completed before filling. This signal output is valid after the unlock bag is completed. Until the lower limit input is valid.
<b>O35</b>	Holder Down	Used to control the downstream of the controlling bracket . ( When there is a bag making function, it needs to be started after the bag is finished ) .
<b>O36</b>	Convery A	Electric mode, for controlling the operation of the belt <b>A</b> , the unlock bags, the hook after the song, the signal is valid.
<b>O37</b>	Convery B	Electric mode, for controlling operation of the belt <b>B</b> , the belt <b>A</b> is stopped, the signal is valid.
<b>O38</b>	Over( PLC )	This signal is valid when it is out of tolerance (PLC ) .
<b>O39</b>	Under(PLC )	This signal is valid when there is a short circuit (PLC ) .
<b>O40</b>	Upper Limit(PLC )	When the weighing value > upper limit value, the upper limit output is valid .
<b>O41</b>	Lower Limit (PLC )	When the weighing value < lower limit, the lower limit output is valid .
<b>O42</b>	Conveyor1	In the bucketless mode, it is used to control the start and stop of the conveyor. The signal is effectively activated by the conveyor and the signal is invalid and the conveyor is stopped.
<b>O43</b>	Coding	The code signal is output when the pocket signal output is valid and the code delay is over.
<b>O44</b>	Sewing	When the sewing machine input is valid, the sewing machine output is valid.
<b>O45</b>	String Cut	After the sewing machine output time is over, the output is valid, and the effective time is the tangential machine output time .
<b>O46</b>	Aux. Pulse1 Ctrl	After the auxiliary pulse <b>input</b> effective, the output pulse signal (valid for the auxiliary pulse <b>aneffective</b> time, dead time of the auxiliary pulse dead time), and outputs the total time to stop the output (the total time is set to <b>0</b> , it has been by Pulse output) .
<b>O47</b>	Aux. Pulse2 Ctrl	After the auxiliary pulse <b>2</b> input is active, the output pulse signal (valid for the auxiliary pulse <b>2effective</b> time, dead time of the auxiliary pulse <b>2dead</b> time), and outputs the total time to stop the output (the total time is set to <b>0</b> , it has been by Pulse output) .
<b>O48</b>	Aux. Pulse3 Ctrl	After the auxiliary pulse <b>3</b> input is valid, the pulse signal is output (the effective time is theauxiliary pulse <b>3</b> valid time, the invalid time is the auxiliary pulse <b>3</b> invalid time ), and after the output execution total time is reached, the output is stopped (the total execution time is set to <b>0</b> , then the button is pressed. Pulse output) .
<b>O49</b>	Aux. Pulse4 Ctrl	After the auxiliary pulse <b>4</b> input is valid, the pulse signal is output (the effective time is theauxiliary pulse <b>4</b> valid time, the invalid time is the auxiliary pulse <b>4</b> invalid time ), and after the

		output execution total time is reached, the output is stopped (the total execution time is set to 0 , then the button is pressed. Pulse output) .
<b>O50</b>	DISC Shaking	The output of the discharge rapping function.
<b>O51</b>	User Logic O1	Output signal of logic programming output 1.
<b>O52</b>	User Logic O2	Output signal of logic programming output 2.
<b>O53</b>	User Logic O3	Output signal of logic programming output 3.
<b>O54</b>	User Logic O4	Output signal of logic programming output 4.
<b>O55</b>	User Logic O5	Output signal of logic programming output 5.
<b>O56</b>	User Logic O6	Output signal of logic programming output 6.
<b>O57</b>	Multi-Function Holder Control Patting Bag	For one - piece control bracket and patting bag. When the patting bag is not executed: this I/O Module is the same as the uplink state of the measuring bracket. When the function of patting bag is on: this I/O Module is opposite to the state of patting bag.(valid patting bag support is invalid, invalid patting bag support is valid).
<b>O58</b>	Conveyor2	Control conveyor 2 output is valid
<b>O59</b>	Conveyor3	Control conveyor 3 output is valid
<b>O60</b>	Conveyor1 Reverse Run	Control conveyor 1 reverse output is valid
<b>O61</b>	Slider PWM	This signal output tractor slider step motor driver pulse signal to control motor rotate. Note: this function only defined one port of OUT12~16
<b>O62</b>	Slider DIR	The signal is used as the motor rotation direction signal output to the tractor slider stepper motor driver to control the motor positive and negative rotation Note: This function can only be defined on one output port. No more than one output port can define this function. The port can be defined to only one port from OUT1 to 11
<b>O63</b>	Clamping Arm PWM	The signal is output to the tractor clip bag stepper motor driver as a pulse signal, control the motor rotation Note: This function can only be defined on ports from OUT12 to 16.
<b>O64</b>	Clamping Arm DIR	The signal is used as the motor rotation direction signal output to the tractor clip bag stepper motor driver to control the positive and negative rotation of the motor. Note: This function can only be defined on one output port. No more than one output port can define this function. The port can be defined to only one port from OUT1 to 11
<b>O65</b>	Bracing Bags Output	Control bag open output
<b>O66</b>	Tractor Output	Control the output of the traction machine
<b>O67</b>	Clamping Arm Lock	Control the output of the traction machine clamp arm
<b>O68</b>	Over	After the over/under tolerance function is turned on, the output is defined, and the signal is valid when it exceeds the tolerance.
<b>O69</b>	Under	After the over/under tolerance function is turned on, define the output. When under tolerance occurs, the signal is valid.
<b>O70</b>	OUT1 Direct	By using the relevant coil address, write 1 and the serial port

	Control	control switch output 1 is valid
<b>O71</b>	OUT2 Direct Control	By using the relevant coil address, write 1 and the serial port control switch output 2 is valid
<b>O72</b>	OUT3 Direct Control	By using the relevant coil address, write 1 and the serial port control switch output 3 is valid
<b>O73</b>	OUT4 Direct Control	By using the relevant coil address, write 1 and the serial port control switch output 4 is valid
<b>O74</b>	OUT5 Direct Control	By using the relevant coil address, write 1 and the serial port control switch output 5 is valid
<b>Input</b>		
<b>I0</b>	None	If the port number is defined as <b>0</b> , this input port is undefined.
<b>I1</b>	Start	The signal valid controller will enter the running state. This input is a pulse input signal.
<b>I2</b>	E-Stop	The signal valid controller will return to the stop state. This input is a pulse input signal.
<b>I3</b>	Stop	The signal valid controller will return to the stop state after completing the current bagging process. This input is a pulse input signal.
<b>I4</b>	Pause	The signal valid controller will suspend work, retain the current state, and resume working after receiving the start signal. This input is a pulse input signal.
<b>I5</b>	ZERO	The signal valid controller will clear the weight. This input is a pulse input signal.
<b>I6</b>	Clear Alarm	Used to clear the alarm output of the controller. This input is a pulse input signal.
<b>I7</b>	Bag Lock/Unlock Request	It is used to control the action of the pocket mechanism. This input is effective for one pocket output, and the effective pocket output is invalid again (ie: unlock bag).
<b>I8</b>	Clear Total ACUM	Clearing the total accumulated weight and number of times will also clear the recipe accumulation and user accumulation .
<b>I9</b>	Manual DISC (button)	Used to manually remove material from the measuring hopper. The input is effective once, the discharge output is valid, and the effective discharge output is invalid again.
<b>I10</b>	Manual Fi-Fill(button)	The input is valid once and the output is valid, and the effective fine input is invalid again.
<b>I11</b>	Manual Co-Fill(button)	Pulse type signal. Function in the stop state, used to manually turn the controller on and off. Effective once, it is effectively turned off again.
<b>I12</b>	Empty Material	Pulse type signal. Acting in the stop state, used to empty the storage hopper while opening the discharge door and the fill door. Effective once , it is effectively turned off again. (No action in bucket, PLC, valve port, ton package mode)
<b>I13</b>	Change Recipe	This input is valid once, the recipe number is changed to the next target whose value is not zero, and the recipe number with the target value of zero is skipped.
<b>I14</b>	Supplement Full	Used to connect the upper level of the hopper, this input should be level input.
<b>I15</b>	Supplement NotEmpty	Used to connect the lower level of the hopper, this input should be level input. The blanking bit input is invalid or left blank to

		indicate the material shortage. The blanking level input is valid to indicate that there is no shortage of material.
<b>I16</b>	Start/E-stop ( level Signal)	The signal is valid and the controller enters the running state. If it is invalid, it returns to the stop state. This input is a level signal.
<b>I17</b>	Start/Stop ( level Signal)	The signal valid controller enters the running state, and if it is invalid, it returns to the stop state after completing the current bagging process. This input is a level signal.
<b>I18</b>	Manual DISC ( switch)	Used to manually remove material from the measuring hopper. The input effective discharge output is valid, and the input invalid discharge output is invalid.
<b>I19</b>	Manual Fi-Fill (switch)	The signal is effectively fine and the signal output is valid. The signal is invalid and the fine signal output is invalid.
<b>I20</b>	Manual Co-Fill (switch)	The signal is valid and the signal output is valid. The signal is invalid and the signal output is invalid.
<b>I21</b>	Bag Locked	If this input is defined, it effectively indicates that the pocket is in place, and vice versa . No fighting mode: the folder bag has state, the controller must be detected "bag-in place" input active material began to increase, the process of adding material, detecting whether the signal is not valid. This input should be a level input.
<b>I22</b>	DISC Gate Opened Pos.	The unloading mode is set to the normal motor forward and reverse double limit mode to control the unloading: this signal is used as the limit input signal of the discharge door opening door. When the controller detects that the signal is valid, it considers that the discharge door has been opened.
<b>I23</b>	Filler Gate Closed Pos.	When the unloading mode is set to normal motor forward and reverse double limit mode to control unloading: this signal is used as the limit input signal of the filling door closing door. When the controller detects that the signal is valid, it considers that the filling door has been closed.
<b>I24</b>	DISC Gate Closed Pos.	This signal acts as a limit input signal for the discharge door to close the door. When the controller detects that the signal is valid, it considers that the discharge door has been closed.
<b>I25</b>	Bag Released	The pocket mode is set to stepper motor lock unlock bag / motor double limit lock unlock bag mode control lock unlock bag: This signal is used as the limit input signal of the pocket bag unlock bag in place. (Note: This signal is determined by the type of in-position signal and is set to positive logic: when the input signal is valid, it is considered that the pocket mechanism has been unlocked in place ; set to reverse logic: when the input signal is invalid, it is considered that the pocket mechanism has been unlocked in place.)
<b>I26</b>	Sewing Start	When the digital input is valid, the effective output of the sewing machine is started.
<b>I27</b>	Sewing E-- Stop	When the digital input is valid, the sewing machine stops outputting.
<b>I28</b>	Aux. Pulse1 Ctrl	Auxiliary Pulse Input 1 self defined trigger input signal
<b>I29</b>	Aux. Pulse2	Auxiliary Pulse Input 2 self defined trigger input signal



	Ctrl	
I30	Aux. Pulse3 Ctrl	Auxiliary Pulse Input 3 self defined trigger input signal
I31	Aux. Pulse4 Ctrl	Auxiliary Pulse Input 4 self defined trigger input signal
I32	Hanging Lift Bag	Used to control the movement of the bag mechanism.
I33	Holder Up Done	The upper limiter for connecting the controlling bracket, this input should be a pulse input .
I34	Holder Down Done	The lower limiter used to connect the controlling bracket, which should be a pulse input .
I35	Manual Holder Up/Down	The lower limiter for connecting the controlling bracket, this input should be a pulse input .
I36	Holder Down Done	In the electric mode , the stop detection load cell for connecting the belt A , which should be a pulse input .
I37	Conveyer A Stop	In the electric mode, the stop detection load cell for connecting the belt B should be a pulse input. (this parameter is reserved)
I38	Conveyer B Stop	Used to control the motion of the stand, this input is a pulse input. The motion of the stand can be controlled in the stopped state. In the running state, it is the start signal of the motion of the bracket. (this parameter is reserved)
I39	Interlock Input	Used in the double scale mode, the ON/OFF "double scale interlock output" used to connect another controller.
I40	User Logic1 Trigger	Custom trigger input signal for logic programming 1.
I41	User Logic2 Trigger	Custom trigger input signal for logic programming 2.
I42	User Logic3 Trigger	Custom trigger input signal for logic programming 3.
I43	User Logic4 Trigger	Custom trigger input signal for logic programming 4.
I44	User Logic5 Trigger	Custom trigger input signal for logic programming 5.
I45	User Logic6 Trigger	Custom trigger input signal for logic programming 6.
I46	Filling Permission	If the Filling allow input is defined in the I/O Module, judge whether the Filling allow input is valid before the filling process. If it is valid, start the filling process; if not, wait.
I47	DISC Permission	Discharge allow input is only for the hopper structure. If discharge allow input is defined in the I/O Module, it is necessary to judge whether the discharge allow input is valid after setting the value. If it is valid, the discharge process will start; if it is not, it will wait.
I48	Conveyor 1 Manual Forward	At stop status, manual control conveyor starts turning forward(When the emergency stop signal is valid, the forward turning output of conveyor 1 is invalid)
I49	Conveyor 1	Control conveyor starts reversal (When the emergency stop

	Manual Reverse	signal is valid, the reversal turning output of conveyor 1 is invalid)
I50	Limit Position Of Conveyor 2	Conveyor 2 Limit Signal Type
I51	Limit Position Of Conveyor 3	Conveyor 3 Limit Signal Type
I52	Slider Backward Locked	The signal serves as the limit input signal of the slider in place, and the controller considers that the slider is in place when it detects that the signal is valid.
I53	Clamping Arm Bag Released	The signal is used as the limit input signal that the arm lock is in place. When the controller detects that the signal is valid, it considers that the arm lock loose bag is opened.
I54	Cutting Gate Open Pos.	If the input is defined, it indicates that the cutting material is in place, otherwise, it indicates that the cutting material is not in place.
I55	External Alarm Input	The signal is valid, and the instrument emits an alarm, indicating "external input alarm".
I56	Manual End	In operation, the signal input is valid, the instrument automatically enters the set value, and the operation transitions to a slow stop state.
I57	No Level Detection	If the signal is valid once, the instrument will shield the material level function. If it is valid again, the instrument will release the material level shielding.
I58	IN1(Read By COM)	When the input is valid, there will be corresponding valid states in the communication, mainly opening the switch input state for use
I59	IN2(Read By COM)	When the input is valid, there will be corresponding valid states in the communication, mainly opening the switch input state for use
I60	IN3(Read By COM)	When the input is valid, there will be corresponding valid states in the communication, mainly opening the switch input state for use
I61	IN4(Read By COM)	When the input is valid, there will be corresponding valid states in the communication, mainly opening the switch input state for use
I62	IN5(Read By COM)	When the input is valid, there will be corresponding valid states in the communication, mainly opening the switch input state for use

#### 4.9 COM Master Mode

Host mode to communicate with the slave to send commands, using host mode, note the following points.

- ◆ The communication parameters of serial port 2 are fixed in host mode. Only when the communication mode is Modbus-RTU mode can host mode be used, otherwise it is prohibited.
- ◆ In host mode, the starting address is fixed to 1
- ◆ Successful write will return successful send; Failure to write data returns failure to send; when there is no return for a long time, the return send timeout.

- ◆ In host mode, changing the high and low bytes of serial port 2 will change the storage order of data sent to the slave. The high and low bits correspond to each other, and the data can be used when the length is double word.

1. Slave COM ID	Initial value: <b>1</b> ; <b>1 ~99</b> optional.
2. Data length	Initial value: Word. Word/Dword is optional
3. Start address	Initial value: <b>1</b> ; <b>1~65535</b> optional, start at 0X0001 by default.
4. Data To Send	Initial value: <b>0</b> ; <b>0 ~ 999999</b> optional.

## 5. Function

### 5.1 Setting the working mode

The **GM9907- L2** has **five** scale body structures. Choose between the system and the communication - scale structure.

They are net weigher, gross weigher, **PLC** mode, jumbo bag, valve scales .

(Note: Among them, the working mode of the net weigher scale and the gross weigher scale supports the dual scale interlock mode. Other scales do not support the dual scale interlock mode)

### 5.2 Batches

The batch number is used for reminder of the number of packages. When the set number of batches is completed during the automatic running process, the controller issues the batch number to the alarm and stops, waiting for the user to process, the batch number and the alarm output are valid. At this time, press the clear alarm button or make The “Clear Alarm” input signal is valid and the controller will clear the above alarm. If the batch number is set to **0** , the batch number judgment is not performed.

The batch number ranges from **0 to 9999**. The initial default value is **0** (no batch count judgment).

### 5.3 Level control

Due to the different application conditions, the filling device of the storage scale storage bin is divided into **two** types: double material level (upper and lower material level), single material level (lower material level) and no level positioner.

#### 5.3.1 Dual Supplement

The upper and lower material levels are defined, corresponding to the double material level. At this time, the controller has a filling control function, and the control principle is: when the upper and lower material level inputs are invalid, the controller filling output is valid; when the filling level input is valid, the filling output is invalid. At the same time, before each filling ( coarse , medium, fine), the controller will check whether the lower level is valid. If it is invalid, wait for this signal; only when this signal is valid, the filling process starts. During the filling process, the controller does not detect whether the material level signal is valid.

#### 5.3.2 Single Supplement

The blanking level is defined, and the loading level is not defined, corresponding to the single material level. At this point the controller will not perform fill control. Only the fill level is detected before filling. If the material level is invalid, wait for this signal; only when this signal is valid, the filling process starts. During the filling process, the controller does not detect whether the material level signal is valid.

The upper and lower material levels are not defined, corresponding to the situation without the positioner. At this time, the controller does not perform the filling control, and the raw material level is not detected before the filling.

### 5.4 Quick setup

In the stopped state, the quickly modified recipe data is saved in real time.

The data modified during operation, the zero zone value is saved in real time, and other recipe parameters are automatically updated when the next scale is started after exiting the

quick setting interface (the combination mode is to be released after the unlock bag is started and the next scale target value is updated).

The recipe parameters are modified during operation, but when the next scale is updated, the emergency stop signal is entered and the controller is stopped and the recipe is updated immediately.

Modbus can also be carried out at runtime when communicating recipe quantitative value changes, but can not modify the recipe number.

## 5.5 Adaptive function

The adaptive function is a convenient function to adjust the filling speed when the user first uses the controller. When this function is turned on, it will automatically adjust the parameters such as the coarse increase advance amount, the medium increase advance amount, the fine increase advance amount, the coarse add ban time, the medium plus ban time, and the fine add time. The filling process is optimized.

Note:

1. All advances must be zero in order to be used normally.
2. If the drop correction and the adaptive function are turned on at the same time, the drop correction function is forcibly turned off.
3. When the first scale is adaptively started, the scale body must be stable and the current weight is zero.

## 5.6 U disk upgrade software

### 5.6.1 Foreground update process

Proceed as follows:

1. containing the upgrade kit "**tpcbakup**" into the controller
2. Power up the controller, and the message "You are using the mcgsTpc project upgrade package 2.8 , Click 'Yes' to continue,.Click' No 'to exit" !Click "Yes" and the "Download Project" button pops up
3. Click "user project update" button, select GM9907 - L2 engineering began to download
4. Download success, restart automatically

### 5.6.2 Background update process

Proceed as follows:

1. Insert the **USB** flash drive into the computer and create a new " GM9907-L2 " folder in the **USB** flash drive
2. Save the image of " GM9907-L - Logo .bmp " into the " GM9907-L2 " folder;
3. Plug the USB flash disk into the controller, switch to the administrator permissions, go to the Maintenance – Firmware Update interface, long press the blank in the lower right corner of 5s, and Click " Update" button pops up, jump to the upgrade interface, click " Update ", click " Update " again, and the words "Upgrade in process" appear, indicating that the controller is upgrading the background .
4. When the progress bar is finished, the upgrade will be successful after the countdown of 10s and the login interface will be switched to.

## 5.7 U disk upgrade boot interface

Proceed as follows:

1. Save the image file (resolution 800\*480, format.**bmp**) into the root directory of U disk containing the project package (tpcbakup) (Note: the upgrade kit "tpcbakup" is

different from this tpebackup )

2. Insert the USB flash drive into the controller
3. The controller pops up the display box of [USB disk kit], and select "Update startup bitmap".
4. Enter the LOGO selection interface, select the image to be upgraded, and click OK. It will prompt you to restart after successful bitmap update

## 5.8 Decoupling function

Decoupling formula parameters of jumbo bag scale parameters, the hook up for release switch is opened:

Setting value after filling, unlock bag, control equipment bracket downward, downward after, take off the hook, the conveyor start, after decoupling before delay on bracket start up, decoupling upward duration, then execute the uplink pause time, pause time arrives, stent decline, time duration for decoupling.

### Decoupling alarm:

If the bag not release completely switch is opened, during this process, if the current weight value is greater than the weight for bag release check value, the machine will stop and the uncoupled alarm will be stopped. The conveyor performs reversal.

Note: This function is mainly used for prevention. After the filling, the bag can't take off the hook completely. When the conveyor is running, the current weight value will suddenly increase, resulting in controller damage.

## 5.9 Holder Movement Type

Running mode of bracket: Air Without Limit, Motor(Two Limit), Air( Two Limit)  
I/O Module: Holder Up(**O34**)

When the controlling bracket is mounted, the holder up output of the controlling bracket is effective. After the holder up timer of the controlling bracket, the uplink of the controlling bracket is in place. (During operation, after ascending to position, the controller can start peeling and filling, etc.)

When the measuring support goes down, the holder up output of the measuring support is invalid. After the holder down timer, the support goes down in place. (In operation, the controller can start to take off the hook after the downlink is in place)

### Motor(Two Limit):

I/O Module input: Holder Up Done(**I33**), Holder Down Done(**I34**). I/O Module output: Holder Up(**O34**), Holder Down (**O35**).

When the measuring support is mounted, the holder up output of the measuring support is effective, while the holder down output of the measuring support is invalid. Wait for the uplink of the measuring support to be in place. If the support is still not in place within the uplink timeout period, the rising timeout alarm will be given. After the up-flow is in place, the holder up output of the controlling support and the holder down output of the controlling support are invalid.

When the controlling support is in the downward direction, the holder down output of the controlling support is effective, while the holder up output of the controlling support is invalid. If the support is still not in the downward direction within the downward timeout period of the support, the downward timeout alarm will be given. When the downlink is in place, the holder down output of the controlling support and the holder up output of the controlling support are both invalid

### Air( Two Limit):

I/O Module input: Holder Up Done(I33), Holder Down Done(I34). I/O Module output: Holder Up(O34), Holder Down (O35).

When the measuring support is mounted, the holder up output of the measuring support is effective, while the holder down output of the measuring support is invalid. Wait for the uplink of the measuring support to be in place. If the support is still not in place within the uplink timeout period, the rising timeout alarm will be given. After the up-flow is in place, the holder up output of the controlling support is effective, while the holder down output of the controlling support is invalid.

When the controlling support is in the downward direction, the holder down output of the controlling support is effective, while the holder up output of the controlling support is invalid. If the support is still not in the downward direction within the downward timeout period of the support, the downward timeout alarm will be given. When the downlink is in place, the holder down output of the controlling support is effective, while the holder up output of the controlling support is invalid.

### 5.10 Use method of 3 - class conveyor for jumbo bag scale

Three conveyors are placed under the ton-bale balance. Conveyor No. 1 is placed under the ton-bale balance. One bag of materials is placed on conveyor 1 after decoupling. Conveyor 2 is behind conveyor 1. Conveyor 3 is behind conveyor 2. There is a limit switch (approach switch) at the end of conveyor 2 and 3 respectively.

1) If the limit switch (approach switch) of conveyor 3 is invalid, then conveyor 2 and Conveyor 3 will rotate to transport materials to conveyor 3. When the limit switch (approach switch) of conveyor 3 is effective, the rotation of conveyor 3 will stop. Similarly, conveyor 1 transports materials to conveyor 2.

2) When the upper limit switch (proximity switch) of conveyor 2 is in effect, conveyor 1 cannot start operation even though it has been disconnected. When the limit switch (proximity switch) of conveyor 2 is invalid, conveyor 1 rotates to transport materials to conveyor 2.

3) When there are materials in conveyor 3 and Conveyor 2, the forklift truck can shovel the materials away and wait for the next start and rotation.

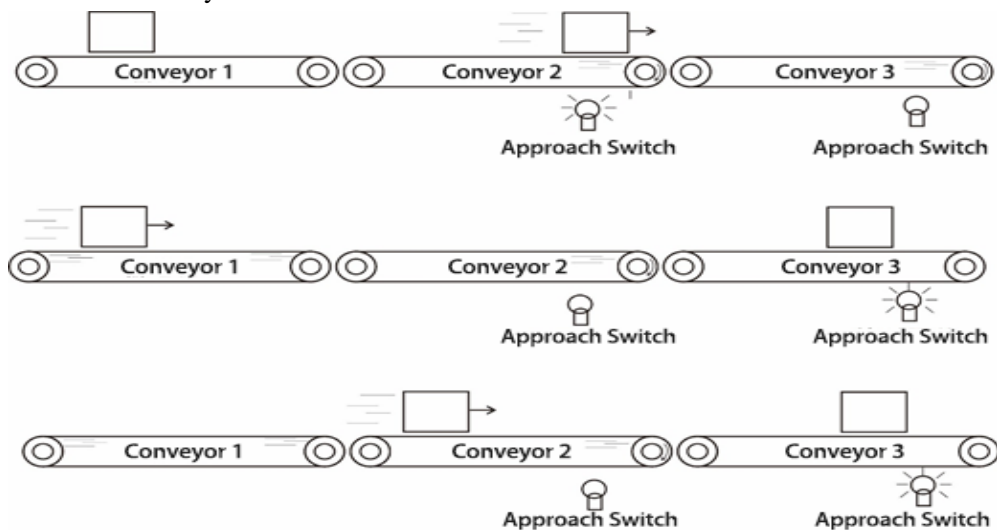

### 5.11 Operation process of various mechanisms in the tractor system

Provide self operation testing functions for each mechanism of the traction system, set the parameters of each mechanism, and ensure normal connection with external mechanism.

limit switches.

On the tractor parameter interface, click the test switch button above the parameter interface of each module. The start test button will appear on the interface. Clicking it will trigger the corresponding test action process and check whether the corresponding mechanism is normal. The operation process of each institution is as follows

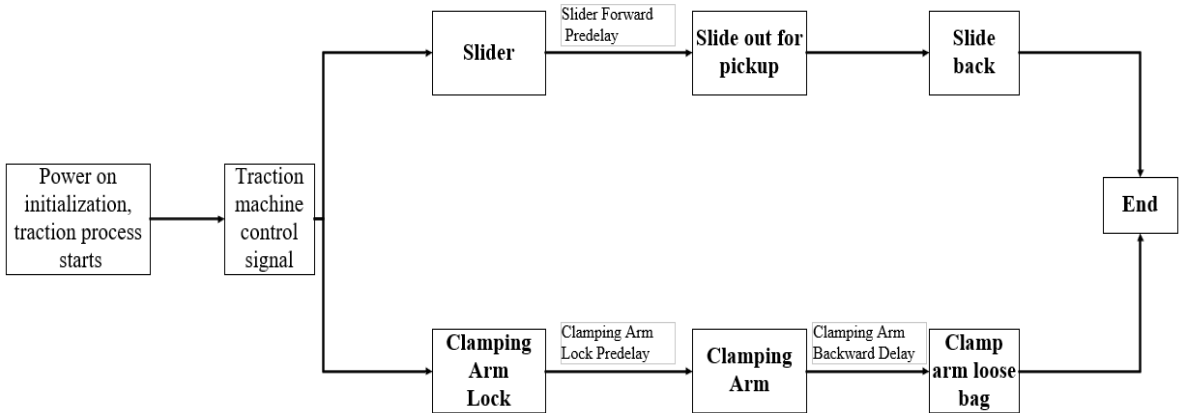



## 6. Serial communication

**GM9907** provides two serial communication interface, and serial port 1 and 2 can be selected in a continuous manner, **modbus** mode and printed three kinds of functions. The first serial port of the controller is **RS-232** and the second serial port of the controller is **RS-485**. And the Ethernet communication is fixed to Modbus TCP protocol, which can cascade instruments.

### 6.1 Printing method

When the serial port serial port **1** or serial port **2** is selected as the **print** mode, the corresponding serial port can realize the printing of the related accumulated content by connecting the serial printer.

The communication parameters related to the printing method refer to the serial port parameter items, among which are noted:

- 1) **Baud Rate** - This parameter should be selected in accordance with the printer settings used for the connection.
- 2) **Communication Format** - This parameter should be selected in accordance with the printer settings used for the connection.  
Note: When the print language is selected as Chinese, the data bit cannot be used in 7-bit format, otherwise there will be an error in printing.
- 3) **Print Format** - The peripheral **format** allows you to set the print format to **24** columns or **32** columns. In addition, the print language of the peripheral parameters is set to Chinese or English.

#### 6.1.1 Auto print

In the **print** mode, the automatic print ON/OFF for peripheral parameters is set to **On**. Then, each time the weighing of the controller is completed, the weighing result will be printed automatically. The format is as follows:

**The English 24 column print format is as follows:**

Packing Detail  
Unit : kg  
Recipe ID : 20  
Total ACUM PCS Result

-----

1	5.50
2	5.50

**The English 32 column print format is as follows:**

Packing schedule  
Unit: kg  
Recipe number: 20  
Total ACUM PCS Target Result

-----

3	5.60	5.50
4	6.00	5.80

#### 6.1.2 Total cumulative printing

In the **print** mode, stop the state, enter the "Statistic" interface, and enter ACUM/ Batch interface, click "Data Edit", click the print total ACUM button to print total ACUM. The format is as follows:

**The English 24 column print format is as follows:**

Total ACUM report

**The English 32 column print format is as follows:**

Total ACUM report

Time: 2018/6/19 13:28

Unit: kg

-----  
PCS: 18

Wt: 84.16  
-----

Time: 2018/6/19 13:36

Unit: kg

-----  
PCS: 24

Wt: 129.40  
-----

### 6.1.3 Recipe cumulative printing

In the printing mode, stop the state, press **【Statistics】** on the main interface to enter the **【Statistics】** interface. Under the **【Recipe ACUM】** parameter, click **【Data Edit】** and select **【Print Select Recipe ACUM Data】** in the pop-up box to select the corresponding recipe for printing.

Click the "Print all recipe ACUM data" to print all the recipes (1 to 20) accumulated, the controller will automatically skip the cumulative recipe 0 does not print. The format is as follows:

**The English 24 column print format is as follows:**

All Recipe ACUM Report

Time: 2018/6/19 13:29

Unit: kg

-----  
Recipe ID: 20

PCS: 18

Wt: 84.16  
-----

**The English 32 column print format is as follows:**

All Recipe ACUM Report

Time: 2018/6/19 13:36

Unit: kg

-----  
Recipe ID: 20

PCS: 24

Wt: 129.40  
-----

### 6.1.4 User cumulative printing

In the printing mode, stop the state, press **【Statistics】** on the main interface to enter the **【Statistics】** interface. Under the **【User ACUM】** parameter, click **【Data Edit】** and select **【Print Select User ACUM Data】** in the pop-up box to select the corresponding recipe for printing.

Click "Print All User ACUM data" to print the total of all users ( 0~9 ). The controller will automatically skip users whose user accumulation is 0 and will not print. The format is as follows:

**The English 24 column print format is as follows:**

All User ACUM Report

Time : 2018/6/19 13:29

Unit : kg

-----  
User ID : 9

PCS : 16

Wt : 72.26

**The English 32 column print format is as follows:**

All User ACUM Report

Time: 2018/6/19 13:37

Unit: kg

-----  
User ID: 9

PCS: 22

Wt: 117.50  
-----



		a part of dual registers. Read-only part is allowed when reading.
<b>01</b>	Reading coil	Note that this length is in bits .
<b>05</b>	Write coil	

Note: This controller only supports the above MODBUS function code. When the controller performs other function codes, the controller will not respond.

◆ MODBUS exception code response

Code	name	meaning
<b>02</b>	Illegal data address	For the controller, the error code indicates that the data address received is an address that is not allowed.
<b>03</b>	Illegal data value	The portion of data written and the allowed range.
<b>04</b>	Slave failure	An unrecoverable error occurs when the controller is attempting to perform the requested operation.
<b>07</b>	Unsuccessful programming request	For the controller, the received command cannot be executed under the current conditions.

#### 6.4.2 MODBUS transmission mode

The MODBUS transmission mode is the RTU mode.

When communication with the RTU mode, information of each **8-bit** byte is divided into **two 4-bit** transmission character **hexadecimal**.

Data format: **8** -bit data bit, **1** stop bit, even parity ( **8-E-1** )

**8** -bit data bit, **1** stop bit, no parity ( **8-N-1** )

Baud rate: **9600/19200/38400/57600/115200** (optional)

Code: **RTU**

#### 6.3.3 MODBUS address allocation

Protocol address	PLC address	Meaning	Description	
<b>0000-0001</b>	<b>40001-40002</b>	GW	Controller display GW value, signed	
<b>0002-0003</b>	<b>40003-40004</b>	NW	Controller display NW value, unsigned	
<b>0004-0005</b>	<b>40005-40006</b>	GW	GW Value	
<b>0006-0007</b>	<b>40007-40008</b>	Control status (bit)	<b>Bit</b>	Description
			D0	Unstable weight : <b>0</b> ; stable : <b>1</b>
			D1	Non-zero : <b>0</b> ; zero : <b>1</b>
			D2	Currently showing the weight of the symbol +/- Positive sign : <b>0</b> ; minus sign : <b>1</b>
			D3	Overflow
			D4	Weight overflow
			D5	Negative weight overflow
			D6	Load cell is overflowing
			D7	Load cell negative overflow
			D8	Millivolts stable: <b>1</b> unstable: <b>0</b>
			D9~31	Reserved
<b>0008-0009</b>	<b>40009-40010</b>	Operating status	D0	<b>0</b> : Stop; <b>1</b> : Run
			D1	Before filling
			D2	Coarse Flow
			D3	Medium Flow
			D4	Fine Flow

			D5	Result Checking
			D6	Ready
			D7	Discharge
			D8	(-NZ-)
			D9	Over
			D10	Under
			D11	Qualified
			D12	OVER/UNDER Pause
			D13	Bag Lock
			D14	Lifting Bag ( valve )
			D15	Pushing bag (valve )
			D16	Hanging bag (jumbo bag )
			D17	AirBlowing ( jumbo bag )
			D18	Return Valve (jumbo bag )
			D19	Hanger Up ( jumbo bag )
			D20	Hanger Down (jumbo bag )
			D21	Upper limit( PLC mode )
			D22	Lower limit( PLC mode )
			D23	Batch complete
			D24	Alarm
			D25	Gross weight status: <b>1</b> : Net : <b>0</b> : Gross
			D26	Clear
			D27	OverLimit (PLC)
			D28	UnderLimit (PLC)
			D29	In the non-bucket mode, after unlock the bag, the mark is valid until the end of this filling
			D30	Stop
			D31	Pause
<b>0010-0011</b>	<b>40011-40012</b>	Control state 2	D0	Dual scale Interlock Output (interlock mode )
			D1	Supplement Full
			D2	Supplement Empty
			D3	FILL
			D4	EMPT
			D5	Cutting Material
			D6	Pat Bag
			D7	Coding
			D8	DISC Patting Output
			D9	Conveyor Start
			D10	Sewing output
			D11	Cutter Output
			D12	Aux. Pulse1 Ctrl Output
			D13	Aux. Pulse2 Ctrl Output
			D14	Aux. Pulse3 Ctrl Output
			D15	Aux. Pulse4 Ctrl Output
			D16	User Logic Output <b>1</b>
			D17	User Logic Output <b>2</b>
			D18	User Logic Output <b>3</b>
			D19	User Logic Output <b>4</b>
			D20	User Logic Output <b>5</b>
			D21	User Logic Output <b>6</b>

			D22	Convery <b>A</b> ( ton pack )
			D23	Convery <b>B</b> ( ton pack )
			D24	Manual Filling
			D25	Manual Discharge
			D26	IN1(Read By COM)
			D27	IN2(Read By COM)
			D28	IN3(Read By COM)
			D29	IN4(Read By COM)
			D30	IN5(Read By COM)
			D31	OUT1 Direct Control
<b>0012~0013</b>	<b>40013~40014</b>	Control state 3	<b>D0</b>	OUT2 Direct Control
			<b>D1</b>	OUT3 Direct Control
			<b>D2</b>	OUT4 Direct Control
			<b>D3</b>	OUT5 Direct Control
			<b>D4</b>	Manual End
			<b>D5</b>	No Level Detection
			<b>D6-15</b>	Reserve
<b>0014-0015</b>	<b>40015-40016</b>	Automatic clear alarm	D0	Target Value Can Not Be 0
			D1	Can Not Run When Weight OFL
			D2	Over Zero Range!
			D3	Non-Stable
			D4	Over/Under Alarm
			D5	Beyond Discharge gate Limitation
			D6	Reserved
			D7	Running,Zero Disabled
			D8	Over Zero Range When AutoZero
			D9	Automatic zeroing instability
			D10	Filler Gate Close Err
			D11	DISC Gate Close Err
			D12	Fi-Filling Gate Open Width Not be 0
			D13	Me-Filling Gate Open Can Not Narrower Than Fi-Filling
D14	Co-Filling Gate Open Can Not Narrower Than Me-Filling			
D15	Co-Filling Gate Open Can Not Narrower Than Fi-Filling			
D16	Running Stable Timeout			
<b>0016~0019</b>	<b>40017~40020</b>	Reserved		
<b>0020-0021</b>	<b>40021-40022</b>	Manually clear the alarm	D0	Batch Completed!
			D1	Over/Under Pause
			D2	Filling Gate Close OverTime t
			D3	Bag Lock OT
			D4	Bag Unlock OT
			D5	DISC Gate Close Overtime
			D6	DISC Gate Open OverTime
			D7	Reserved
			D8	Reserved
			D9	Internal Communication Failed
			D10	Co-Fill OverTime
			D11	Me-Fill OverTime
			D12	Co-Fill OverTime
			D13	DISC OverTime
D14	Discharge Patting OT			

			D15	Uncoupled alarm I/O
			D16	Hanger rise overtime alarm
			D17	Hanger down overtime alarm
			D18	Motor mid filling in place alarm
			D19	Motor fine filling in place alarm
			D20	Slider Backward Timeout
			D21	UnClamping Arm Timeout
			D22	External Alarm Input
			D23	Bag Lost Alarm
0022~0025	40023~40026	Reserved		
0026-0027	40027-40028	Calibration alarm	Capacity Low	
			Capacity Over	
			Zero Voltage Over	
			Zero Voltage Low	
			Input Unstable	
			Gain Voltage Over	
			Gain Voltage Low	
			Input Unstable	
			Weight Error	
Over Resolution				
0028-0029	40029-40030	Alarm 3	Reserved	
Real time parameters,Read only				
0030-0031	40031-40032	Total cumulative weight is 6digits		
0032-0033	40033-40034	The total cumulative weight low 9		
0034-0035	40035-40036	Total accumulated number of packets		
0036-0037	40037-40038	Current formula cumulative weight is 6 digits high		
0038-0039	40039-40040	The current recipe cumulative weight low 9		
0040-0041	40041-40042	Current formula cumulative number of packages		
0042-0043	40043-40044	User cumulative weight is 6digits		
0044-0045	40045-40046	User cumulative weight is 9digits lower		
0046-0047	40047-40048	User cumulative number of packets		
0048	40049	Batch remaining		
0049	40050	Coarse Flow Timer		
0050	40051	Medium Flow Timer		
0051	40052	Fine Flow Timer		
0052	40053	Result Waiting Timer		
0053	40054	Discharge timer		
0054	40055	Previous package timer ( Coarse timer + medium timer +fine timer + Result Waiting timer + Discharge timer + Filling Start Delay timer )		
0055-0056	40056-40057	Previous bag weight		
0057-0058	40058-40059	Packing speed		
0059-0060	40060-40061	Flow rate		
0061	40062	Filling Start Delay		
0062~0099	40063~40100	Reserved		
Calibration parameters (reserved 100~200 )				
0100	40101	Unit	Initial value : 1 ; 0 : g , 1 : kg , 2 : t , 3 : lb	
0101	40102	Decimal point	Initial value:2; Option: 0—0; 1—1 ; 2—2 ; 3—3 ; 4—4	
0102	40103	Division	Initial value: 1 ; Optional: ( 1/ 2/ 5/ 10/ 20/ 50 ) .	
0103-0104	40104-40105	Full Scale	Initial value: 10000 ; Write range (maximum range value minimum scale $\leq \times 10$ 0000, andnot more than 999,999)	

0105-0106	4010640107	Calibration Zero	When writing <b>1</b> to the current weight as zero, the weighing is allowed to be written when the weighing platform is stable; the current zero millivolt is returned when reading.
0107-0108	40108-40109	Weight calibration	Enter the standard weight weight ( $\leq$ maximum range) ; Read as the current load cell relative zero millivolts
0109-0110	40110-40111	Weightless Gain Calibration (Millivolts)	Write the millivolts corresponding to the gain weight, the controller is temporarily stored; <b>when reading, it returns the absolute millivolts corresponding to the current weight</b> ( if the current millivolt is too small or too large, it cannot be calibrated and returns <b>0XFFFF</b> . ).
0111-0112	40112-40113	No code gain calibration (weight)	Write and gain the weight value corresponding to millivolts. Before writing this value, you must first write the gain millivolts. When writing this register, use both to perform gain calibration. Returns <b>0000H</b> when read .
0113	40114	Load cell sensitivity	<b>3mV/V</b>
0114-0115	40115-40116	Controller load cell voltage	The multicontroller measures the voltage between <b>EX +</b> and <b>EX -</b> . (Note 2) .
0116-0117	40117-40118	Load cell maximum range	Initial value: <b>10000</b> ; ( Note 2 ) . Write range (maximum range value minimum scale $\leq \times 10\ 0000$ , and not more than <b>999,999</b> )
0118-0119	40119-40120	Filling time	Initial Value:0.0s Write range:0~99.9s
0120-0121	40121-40122	Calibration By Supplement	Write the weight value corresponding to the gain millivolts; Press "manual discharge" to record the current relative millivolt, and use the two to calibrate the gain when writing this register; Return 0000H on read.
0122~0199	40123~40200	Reserved	
Weighing parameter(1)			
0200	40201	STAB Range	Initial value : <b>2</b> ; Range: <b>0 ~99d</b>
0201	40202	STAB Time	Initial value: <b>0.3</b> ; range: <b>0.1~9.9</b> . (unit s )
0202	40203	Zero Range	Initial value: <b>50</b> ; Range : <b>1 -99 %</b>
0203	40204	TrZero Range	Initial value: <b>0</b> ; Range : <b>0-9d</b>
0204	40205	TrZero Time	Initial value: <b>2.0</b> ; range: <b>0.1~99.9</b> . (unit s )
0205	40206	Sampling Rate	Initial value: <b>1</b> Optional: <b>0:120SPS;1:240 SPS; 2: 480 SPS; 3: 960SPS</b>
0206~0249	40207~40250	Reserved	
System and communication parameters - filter parameters			
0250	40251	Digital Filter	Initial value: <b>7</b> ; Range: <b>0 to 9</b>
0251	40252	Vib-Filter	Initial value: <b>0</b> ; <b>1</b> : On <b>0</b> : Off
0252	40253	Dynamic Filter	Initial value: <b>0</b> ; <b>1</b> : On ; <b>0</b> : Off
0253	40254	Filling Filter Level	Initial value: <b>2</b> ; Range: <b>0 to 9</b>
0254	40255	Result Check Filter	Initial value: <b>7</b> ; Range: <b>0 to 9</b>
0255	40256	Discharge Filter	Initial value: <b>1</b> ; Range: <b>0 to 9</b>
0256~0299	40257~40300	Reserved	
Weighing parameter (3)			



0300	40301	PWR-ON Zero	Initial value: 0 ; 1 : On ; 0 : Off
0301	40302	Fill PreZero Interval	Initial value: 0 ; Range : 0-99 has the bucket to complete the packing and then clear the current weight.
0302	40303	Running Stable Timeout	The initial value is 0 ; the range is 0 to 99.9 . (unit s )
0303	40304	Result Checking Mode	Initial value: 0 ; (range: 0 , 1 ) 0 : Stable Status ; 1 : Delay Timer
0304	40305	Manual DISC To ACUM	Initial value: 0 ; 1 : On ; 0 : Off
0305	40306	Result Hold	Initial value: 0 ; 1 : On ; 0 : Off
0306	40307	Adaptive Level	Initial value: 3 ; Range: 1 ~ 5
0307	40308	Adaptive ON/OFF	Initial value: 0 ; Range: 0 ~ 2
0308	40309	Manual Unlock Bag	Initial value: 0 ; 1 : On ; 0 : Off
0309	40310	Hanging Bag Control	Initial value: 0 ; 1 : On ; 0 : Off
0310	40311	Hanging Bag Reverse Logic	Initial value: 0 ; 1 : On ; 0 : Off
0311	40312	Tare Detect	Initial value: 0 ; 1 : On ; 0 : Off
0312	40313	Allow Unlock Bag When Fill	Initial value: 0 ; 1 : On ; 0 : Off
0313~0349	40314~40350	Reserved	
<b>System and communication parameters - structural parameters</b>			
0350	40351	Scale Structure	Initial value: 0 ; 0 : With Hopper; 1 : No Hopper; 2 : PLC mode; 3 : ton scale; 4 : Valve scale.
0351	40352	Working Mode	Initial value : 0 ; 0: single scale; 1: Dual Scale: Master ;2: Dual Scale: Slave
0352	40353	G/N Packing	Initial value: 1 ; 0: Gross ; 1:Net
0353	40354	Hanger Movement Type	Initial value: 0 ; 0 :Air Without Limit; 1 : Motor(Two Limit);2: Air( Two Limit)
0354	40355	Filling Ctrl Mode	Initial value: 1 ; 0 : Single Ctrl; 1 : Combo Ctrl
0355	40356	Dual Scale Unlock Bag Mode	Initial value: 0 ; 0 : Asynchro Unlock; 1 : Synchro Unlock1; 2 : Synchro Unlock2.
0356	40357	Holder control ON/OFF	Initial value: 0; 0: OFF; 1: ON
0357~0499	40358~40500	Reserved	
<b>Recipe parameters-Fulling Values parameters</b>			
0500-500	40501-40502	Recipe ID	Initial value 1 ; range: 1 to 20
0502-0503	40503-40504	Target	Weight value writing range : ≤maximum range
0504-0505	40505-40506	Co-Fi Remains	
0506-0507	40507-40508	Me-Fi Remains	
0508-0509	40509-40510	Free Fall	
0510-0511	40511-40512	Near Zero Band	
0512-0513	40513-40514	Adaptive Level	Initial value 3 ; range: 1 to 5
0514-0515	40515-40516	Adaptive	Initial value 0 ; range: 0 to 2

		ON/OFF	
0516-0517	40517-40518	Permanent Replace	Initial value 0 ; range: 0: OFF; 1: ON
0518~0549	40519~40550	Reserved	
Recipe parameter - time parameter			
0550	40551	Filling PreDelay Timer	Initial value: 0.5 ; range: 0 to 99.9 . (unit s )
0551	40552	COMP.Inhibit Timer(Co-F)	. Initial value: 09; range: 0 to 99.9 . ( s )
0552	40553	COMP.Inhibit Timer(Me-F)	Initial value: 0.9 ; range: 0 to 99.9 . ( s )
0553	40554	COMP.Inhibit Timer(Fi-F)	Initial value: 0.9 ; range: 0 to 99.9 . ( s )
0554	40555	Result Waiting Timer	Initial value: 0.5 ; range: 0 to 99.9 . ( s )
0555	40556	Bag Locked Delay Timer	Initial value: 0.5 ; range: 0 to 99.9 . ( s )
0556	40557	Unlock Bag Pre-Delay Timer	Initial value: 0.5 ; range: 0 to 99.9 . ( s )
0557	40558	Discharge Delay Timer	Initial value: 0.5 ; range: 0 to 99.9 . ( s )
0558~0599	40559~40600	Reserved	
Over/Under Parameter			
0600	40601	OVER/UNDER ON/OFF	Initial value: 0 ; 1 : On ; 0 : Off
0601	40602	OVER/UNDER Pause	Initial value: 0 ; 1 : On ; 0 : Off
0602	40603	OVER/UNDER Alarm Timer	Initial value: 10; range: 0 ~999 ( s )
0603-0604	40604-40605	Over Limit Value	Weight value writing range : ≤maximum range
0605-0606	40606-40607	Under Limit Value	
0607	40608	Fill Compensation	Initial value: 0 ; 1 : On ; 0 : Off.
0608	40609	Compensation Times	First: 1; range: 1 ~ 99.
0609	40610	Fill-ON Timer	Initialvalue: 0.5; range: 0 to 99.9 ( s )
0610	40611	Fill-OFF Timer	Initialvalue: 0.5; range: 0 to 99.9 ( s )
Auto Free Fall Correction Parameter			
0611	40612	FreeFall Correction ON/OFF	Initial value: 0 ; 1 : On ; 0 : Off .
0612	40613	Reference Samples PCS	Initial value: 1 ; Range: 1-99 .
0613	40614	Correction Effective Range	Range: 2.0 ; Range: 0 to 9.9 ( % )
0614	40615	Correction Percentage	Initial value: 1 ; Optional: 0--100 % correction; 1--50% correction; 2 - 25%correction.
Jog Flow Parameter			
0615	40616	Jog Flow ON/OFF	Initial value: 0; 1: On; 0: Off.
0616	40617	Jog Flow-ON Timer	Initial value: 0.5; range: 0 to 9.9 . ( s )

<b>0617</b>	<b>40618</b>	Jog Flow-OFF Timer	Initial value: <b>0.5</b> ; range: <b>0 to 99.9</b> . ( s )
Net Weigher Parameter			
<b>0618</b>	<b>40619</b>	Filling Combination Times	First: <b>1</b> ; range: <b>0 ~ 99</b> .
<b>0619</b>	<b>40620</b>	Binyes Multi- scale Switch	Initial value: <b>0</b> ; <b>1</b> : On; <b>0</b> : Off.
<b>0620~0621</b>	<b>40621~40622</b>	Total Target Value	It will only work when the multi scale switch is turned on
<b>0622~0649</b>	<b>40623~40650</b>	Reserved	
Gross Weigher Scale Parameter			
<b>0650</b>	<b>40651</b>	Next Filling Lock Bag PreDelay	Initial value: <b>4.0</b> ; range: <b>0 to 99.9</b> . ( s )
<b>0651</b>	<b>40652</b>	Bag Lost Detect Time	Initial value: <b>0.0</b> ; range: <b>0 to 99.9</b> . ( s ) ( Suitable for gross weigher scales and valve scales )
<b>0652-0653</b>	<b>40653-40654</b>	Bag Lost Detect Weight	Range: <b>0 ~ Full Scale</b> ( Suitable for gross weigher scales and valve scales )
<b>0654~0699</b>	<b>40655~40700</b>	Reserved	
PLC Parameter			
<b>0700-0701</b>	<b>40701-40702</b>	PLC-OverLimit Value	<b>0 ~ Full Scale</b>
<b>0702-0703</b>	<b>40703-40704</b>	PLC- UnderLimit Value	<b>0 ~ Full Scale</b>
<b>0704-0705</b>	<b>40705-40706</b>	PLC- UpperLimit Value	<b>0 ~ Full Scale</b>
<b>0706-0707</b>	<b>40707-40708</b>	PLC- LowerLimit Value	<b>0 ~ Full Scale</b>
<b>0708~0749</b>	<b>40709~40750</b>	Reserved	
Jumbo bag Scale Parameter			
<b>0750</b>	<b>40751</b>	Hang Up Bag Delay	Initialvalue: <b>0.5</b> ; range: <b>0 to 99.9</b> ( s )
<b>0751</b>	<b>40752</b>	Holder Control	Optional:0:Auto Up And Down, 1:Auto Up Manual Down, 2:Manual Up Auto Down, 3:Manual Up Manual Down; Initial value: 0:Auto Up And Down.
<b>0752</b>	<b>40753</b>	Holder Up Timer	Initial value: <b>5.0</b> ; range: <b>0 ~ 99.9</b> ( s )
<b>0753</b>	<b>40754</b>	Holder Down Timer	Initial value: <b>5.0</b> ; range: <b>0 ~ 99.9</b> ( s )
<b>0754</b>	<b>40755</b>	Holder Up OverTime	Initial value: <b>5.0</b> ; range: <b>0 ~ 99.9</b> ( s )
<b>0755</b>	<b>40756</b>	Holder Down OverTime	Initial value: <b>5.0</b> ; range: <b>0 ~ 99.9</b> ( s )
<b>0756</b>	<b>40757</b>	Air Blow Timer	Initialvalue: <b>0.5</b> ; range: <b>0 ~ 99.9</b> ( s )
<b>0757</b>	<b>40758</b>	Hook Up For Release ON/OFF	Initial value: <b>0</b> ; <b>1</b> : On; <b>0</b> : Off.
<b>0758</b>	<b>40759</b>	Bag Not Release Completely ON/OFF	Initial value: <b>0</b> ; <b>1</b> : On; <b>0</b> : Off.

0759	40760	Hang Up Bag Time	Initialvalue: <b>0.0</b> ; range: <b>0 to 99.9</b> ( s )
0760	40761	Blowing Mode	Initial value: 0. 0: Uplink delay before blowing 1: Uplink delay after blowing
0761	40762	Rlief Valve Mode	Initial value: 0; 0: Close the return valve after filling; 1: close the return valve after unlock bag
0762	40763	Pre-Delay of Hook Up	Initialvalue: <b>0.0</b> ; range: <b>0 to 99.9</b> ( s )
0763	40764	Hook Up Time	Initialvalue: <b>0.0</b> ; range: <b>0 to 99.9</b> ( s )
0764	40765	Hook Up pause time	Initialvalue: <b>0.0</b> ; range: <b>0 to 99.9</b> (t s )
0765	40766	Conveyor REV. Time	Initialvalue: <b>0.0</b> ; range: <b>0 to 99.9</b> ( s )
0766~0767	40767~40768	Weight For Bag Release Check	0~maximum range
0768~0799	40769~40800	Reserved	
Valve Scale Parameter			
0800	40801	Delay Before Lifting Bag	Initialvalue : <b>0.5</b> ; range: <b>0 to 99.9</b> . (s)
0801	40802	Lifting Bag Timer	Initialvalue : <b>0.5</b> ; range: <b>0 to 99.9</b> . (s)
0802	40803	Delay Before Pusing Bag	Initialvalue : <b>0.5</b> ; range: <b>0 to 99.9</b> . (s)
0803	40804	Pushing Bag Timer	Initialvalue : <b>0.5</b> ; range: <b>0 to 99.9</b> . (s)
0804~0849	40805~40850	Reserved	
Process Parameter- Fast Mode			
0850	40851	Fast Mode ON/OFF	Initial value: <b>0</b> ; <b>1</b> : On; <b>0</b> : Off.
0851	40852	Fast Mode Timer	Initial <b>value: 50</b> ; range: <b>0 ~ 1000</b> (ms )
0852~0853	40853~40854	Fast Mode Weight	Fast mode cut-off weight value. Initial <b>value: 0</b> ; range: 0~maximum range
0854	40855	Fast Mode Correction	Initial <b>value: 5</b> ; range: <b>0 ~ 99</b> .
0855	40856	Stabilization Timer	Initial <b>value: 100</b> ; range: <b>0 ~ 1000</b> (ms )
0856~0999	40857~41000	Reserved	
Peripherals parameter-Patting Parameter			
1000	41001	Patting Mode	Initial value: <b>0</b> ; Optional: <b>0</b> : Disable ; <b>1</b> : After Waiting ; <b>2</b> : When Filling ; <b>3</b> : All time . Net weigher Can Write: <b>0,1</b> ; The multi scale switch is turned on and can be set from <b>0 to 3</b> Gross weigher,jumbo bag and valve scale Can Write: <b>0~3</b> .
1001-1002	41002-41003	Start-Up Weight 1	Initial value: <b>0</b> ; Range: <b>0 ~Maximum</b> range.
1003	41004	Patting Times(Filling) 1	Initial value: <b>0</b> ; range: <b>0~99</b> . Set the parameters for the number of shots in the fill .
1004	41005	Patting Times(HOLD)	Initial value: <b>4</b> ; Range: <b>0~99</b> . Set the parameters for the number of shots after the value is set .

1005	41006	Patting PreDelay Timer	Initial value: <b>0.5</b> ; range : <b>0~99.9</b> . (s) After the bag is started , the bag output is valid after this delay time.
1006	41007	Patting ON Timer	Initial value: <b>0.5</b> ; range: <b>0~99.9</b> . (s) During the on-off cycle of the bag, the bag output valid time.
1007	41008	Patting OFF Timer	Initial value: <b>0.5</b> ; range : <b>0~99.9</b> . (s) In the on-off cycle of the bag, the bag output invalid time.
1008	41009	Extra Patting Timer	Initialvalue: <b>0</b> ; range : <b>0~99.9</b> ( s )
1009-1010	41010-41011	Start-Up Weight 2	Initial value: <b>0</b> ; Range: <b>0</b> ~Maximum range.
1011	41012	Patting Times(Filling) 2	Initial value: <b>0</b> ; Range: <b>0~99</b> . Parameter for bag tapping frequency during feeding.
1012-1013	41013-41014	Start-Up Weight 3	Initial value: <b>0</b> ; Range: <b>0</b> ~Maximum range.
1014	41015	Patting Times(Filling) 3	Initial value: <b>0</b> ; Range: <b>0~99</b> . Parameter for bag tapping frequency during feeding.
1015~1019	41016~41020	Reserved	
Peripherals parameter-Coding Parameter			
1020	41021	Coding Device ON/OFF	Initial value: <b>0</b> ; <b>1</b> : On ; <b>0</b> : Off .
1021	41022	Coding Start Delay Timer	Initialvalue: <b>0.5</b> ; range: <b>0 to 99.9</b> ( s )
1022	41023	Coding Timer	Initialvalue: <b>0.5</b> ; range: <b>0 to 99.9</b> ( s )
1023	41024	Disable Fill/Discharge When Coding	Initial value: <b>0</b> ; <b>0</b> : The discharge output or the fill output is allowed to start during the coding process; <b>1</b> : The discharge output or fill output is not allowed to start during the coding process.
1024~1029	41025~41030	Reserved	
Peripherals parameter-Sewing Parameter			
1030	41031	Sewing Start Delay Timer	Initialvalue: <b>0.5</b> ; range: <b>0 to 99.9</b> (s)
1031	41032	Sewing ON Timer	Initialvalue: <b>4.0</b> ; range: <b>0 to 99.9</b> (s)
1032	41033	String Cut ON Timer	Initialvalue: <b>0.5</b> ; range: <b>0 to 99.9</b> (s)
1033	41034	Sewing Stop Delay Timer	Initialvalue: <b>0.5</b> ; range: <b>0 to 99.9</b> (s)
1034	41035	Cutter PreDelay Timer	Initialvalue: <b>0.5</b> ; range: <b>0 to 99.9</b> (s)
1035	41036	Sewing Switch	Initialvalue: <b>0</b> ; <b>1</b> : ON; <b>0</b> : OFF
1036	41037	Sewing Debounce Timer	Initialvalue: <b>0.3</b> ; range: <b>0~99.9</b> .
1037~1039	41038~41040	Reserved	
Peripherals parameter- DISC Shaking Parameters			
1040	41041	DISC Shaking Switch	Initial value: <b>0</b> ; <b>0</b> : Off. <b>1</b> : Individual Shaking ; <b>2</b> : DISC Shaking (DISC);
1041	41042	DISC Shaking Trigger Time	Initialvalue: <b>2.0</b> ; range: <b>0 to9.9</b> (s)

1042	41043	DISC Shaking ON Timer	Initialvalue: <b>0.5</b> ; range: <b>0 to9.9</b> (s)
1043	41044	DISC Shaking OFF Timer	Initialvalue: <b>0.5</b> ; range: <b>0 to9.9</b> (s)
1044	41045	DISC Shaking Times	Initial value: <b>10</b> ; Range: <b>0 to 99</b> .
<b>1045~1049</b>	<b>41046~41050</b>	Reserved	
<b>Peripherals parameter- Fill&amp; DISC OverTime Alarm parameter</b>			
1050	41051	Fill& DISC OverTime Switch	Initial value: <b>0</b> ; <b>1</b> : On ; <b>0</b> : Off .
1051	41052	Co-Fill OverTime	Initial value: <b>5.0</b> ; range: <b>0 to 99.9</b> . (s)
1052	41053	Me-Fill OverTime	Initial value: <b>5.0</b> ; range: <b>0 to 99.9</b> . (s)
1053	41054	Fi-Fill OverTime	Initial value: <b>5.0</b> ; range: <b>0 to 99.9</b> . (s)
1054	41055	DISC OverTime	Initial value: <b>5.0</b> ; range: <b>0 to 99.9</b> . (s)
<b>1055~1059</b>	<b>41056~41060</b>	Reserved	
<b>Peripherals parameter-Auxiliary Pulse Parameter</b>			
1060	41061	Aux. Pulse 1 Execute Time	Initial value: <b>0.0</b> ; Range: <b>0 to 999.9</b> . (s)
1061	41062	Aux. Pulse 1 ON Time	Initial value: <b>10.0</b> ; Range: <b>0 to 999.9</b> . (s)
1062	41063	Aux. Pulse 1 OFF Time	Initial value: <b>10.0</b> ; Range: <b>0 to 999.9</b> . (s)
1063	41064	Aux. Pulse 2 Execute Time	Initial value: <b>0.0</b> ; Range: <b>0 to 999.9</b> . (s)
1064	41065	Aux. Pulse 2 ON Time	Initial value: <b>10.0</b> ; Range: <b>0 to 999.9</b> . (s)
1065	41066	Aux. Pulse 2 OFF Time	Initial value: <b>10.0</b> ; Range: <b>0 to 999.9</b> . (s)
1066	41067	Aux. Pulse 3 Execute Time	Initial value: <b>0.0</b> ; Range: <b>0 to 999.9</b> . (min )
1067	41068	Aux. Pulse3 ON Time	Initial value: <b>10.0</b> ; Range: <b>0 to 999.9</b> . (min )
1068	41069	Aux. Pulse 3 OFF Time	Initial value: <b>10.0</b> ; Range: <b>0 to 999.9</b> . (min )
1069	41070	Aux. Pulse 4 Execute Time	Initial value: <b>0.0</b> ; Range: <b>0 to 999.9</b> . (min )
1070	41071	Aux. Pulse 4 ON Time	Initial value: <b>10.0</b> ; Range: <b>0 to 999.9</b> . (min )
1071	41072	Aux. Pulse 4 OFF Time	Initial value: <b>10.0</b> ; Range: <b>0 to 999.9</b> . (min )
1072	41073	Aux. Pulse Control 1	Initial value: 0; 0—ON/OFF Pulse Mode , 1—Always ON
1073	41074	Aux. Pulse Control 2	
1074	41075	Aux. Pulse Control 3	
1075	41076	Aux. Pulse Control 4	
1076	41077	Auxiliary Pulse Switch	Initial value: <b>0</b> , <b>1</b> : On ; <b>0</b> : Off
<b>1077~1079</b>	<b>41078~41080</b>	Reserved	

Peripherals parameter-Conveyor Parameter			
1080	41081	Conveyor Control	Initial value: <b>0</b> ; <b>0</b> :Disable ; <b>1</b> : <b>1 Conveyor</b> ; <b>2</b> : <b>2 Conveyor</b> ; <b>3</b> : <b>3 Conveyor</b> ;
1081	41082	Conveyor Start Delay Timer	Initialvalue: <b>0.5</b> ; range: <b>0 to 99.9</b> (s)
1082	41083	Conveyor Running Timer	Initialvalue: <b>4.0</b> ; range: <b>0 to 99.9</b> . (s)
1083	41084	Conveyor 2/3 Max Run Timer	Initialvalue: <b>30.0</b> ; range: <b>0~99.9</b>
1084~1089	41085~41090	Reserved	
Communication parameter-Print Parameter			
1090	41091	Auto Print	Initial value: <b>0</b> , <b>1</b> : On ; <b>0</b> : Off
1091	41092	Printer Format	Initial value : <b>0</b> ; <b>0</b> : <b>24</b> columns printing ; <b>1</b> : <b>32</b> columns printing .
1092	41093	Printing Language	Initialvalue : <b>0</b> ; <b>0</b> : Chinese; <b>1</b> : <b>E n g l i s h</b> .
1093	41094	Printing Line Nos.	Initial value: <b>3</b> ; Range: <b>0 to 9</b> .
1094~1199	41095~41200	Reserved	
User Logic- 1			
1200	41201	User Logic Type	Initial value : <b>0</b> ; range <b>0~5</b> . <b>0</b> : Disable <b>1</b> : Delay ON <b>2</b> : Delay OFF <b>3</b> : Delay ON&OFF <b>4</b> : OFF To ON Edge Trigger <b>5</b> : ON To OFF Edge Trigger
1201	41202	Logic Trigger Type	Initial value : <b>0</b> ; range: <b>0~64</b> . Can be selected from the definition of the trigger input port , fixed digital input port <b>1~12</b> , digital output definition, weight value trigger.
1202	41203	Trigger Function(IN)	Initial value : <b>0</b> ; range <b>0~12</b> . Select the digital input port <b>0~12</b> corresponding to this function signal , and input port <b>0</b> means that this function is not defined.
1203	41204	Trigger Function(OUT)	Initial value : <b>0</b> ; range <b>0~16</b> . Select the digital output port <b>0~16</b> corresponding to the function signal , and the output port- <b>0</b> means that the function is not defined.
1204	41205	Delay ON Timer	Initial value : <b>0</b> ; range: <b>0~99.9</b> .(unit s ) After the trigger signal is valid, the logic output signal is valid after the delay.
1205	41206	Delay Timer OFF	Initial value : <b>0</b> ; range: <b>0~99.9</b> .(unit s ) After the trigger signal is invalid, the logic output signal will be invalid after the delay.
1206	41207	Output Timer ON	Initial value : <b>0</b> ; range: <b>0~99.9</b> .(unit s ) The duration after the logic output signal is valid, and becomes invalid after the end of the time.
1207-1208	41208-41209	Logic Trigger Weight	Initial value: <b>0</b> ; Range: <b>0~999999</b> When the trigger signal selects "Threshold Weight", the current weight is compared to this value.
1209~1219	41210~41220	Reserved	
User Logic- 2			
1220	41221	User Logic Type	Initial value : <b>0</b> ; range <b>0~5</b> . <b>0</b> : Disable

			<b>1</b> : Delay ON <b>2</b> : Delay OFF <b>3</b> : Delay ON&OFF <b>4</b> : OFF To ON Edge Trigger <b>5</b> : ON To OFF Edge Trigger
1221	41222	Logic Trigger Type	Initial value : <b>0</b> ; range: <b>0~64</b> . Can be selected from the definition of the trigger input port , fixed digital input port <b>1~12</b> , digital output definition, weight value trigger.
1222	41223	Trigger Function(IN)	Initial value : <b>0</b> ; range <b>0~12</b> . Select the digital input port <b>0~12</b> corresponding to this function signal , and input port <b>0</b> means that this function is not defined.
1223	41224	Trigger Function(OUT)	Initial value : <b>0</b> ; range <b>0~16</b> . Select the digital output port <b>0~16</b> corresponding to the function signal , and the output port- <b>0</b> means that the function is not defined.
1224	41225	Delay ON Timer	Initial value : <b>0</b> ; range: <b>0~99.9</b> .(unit s ) After the trigger signal is valid, the logic output signal is valid after the delay.
1225	41226	Delay Timer OFF	Initial value : <b>0</b> ; range: <b>0~99.9</b> .(unit s ) After the trigger signal is invalid, the logic output signal will be invalid after the delay.
1226	41227	Output Timer ON	Initial value : <b>0</b> ; range: <b>0~99.9</b> .(unit s ) The duration after the logic output signal is valid, and becomes invalid after the end of the time.
1227-1228	41228-41229	Logic Trigger Weight	Initial value: <b>0</b> ; Range: <b>0~999999</b> When the trigger signal selects "Threshold Weight", the current weight is compared to this value.
1229~1239	41230~41240	Reserved	
User Logic- 3			
1240	41241	User Logic Type	Initial value : <b>0</b> ; range <b>0~5</b> . <b>0</b> : Disable <b>1</b> : Delay ON <b>2</b> : Delay OFF <b>3</b> : Delay ON&OFF <b>4</b> : OFF To ON Edge Trigger <b>5</b> : ON To OFF Edge Trigger
1241	41242	Logic Trigger Type	Initial value : <b>0</b> ; range: <b>0~64</b> . Can be selected from the definition of the trigger input port , fixed digital input port <b>1~12</b> , digital output definition, weight value trigger.
1242	41243	Trigger Function(IN)	Initial value : <b>0</b> ; range <b>0~12</b> . Select the digital input port <b>0~12</b> corresponding to this function signal , and input port <b>0</b> means that this function is not defined.
1243	41244	Trigger Function(OUT)	Initial value : <b>0</b> ; range <b>0~16</b> . Select the digital output port <b>0~16</b> corresponding to the function signal , and the output port- <b>0</b> means that the function is not defined.
1244	41245	Delay ON Timer	Initial value : <b>0</b> ; range: <b>0~99.9</b> .(unit s ) After the trigger signal is valid, the logic output signal is valid after the delay.
1245	41246	Delay Timer OFF	Initial value : <b>0</b> ; range: <b>0~99.9</b> .(unit s ) After the trigger signal is invalid, the logic output signal will be invalid after the delay.



1246	41247	Output Timer ON	Initial value : 0 ; range: 0~99.9 .(unit s ) The duration after the logic output signal is valid, and becomes invalid after the end of the time.
1247-1248	41248-41249	Logic Trigger Weight	Initial value: 0 ; range: 0~999999. When the trigger signal selects "Threshold Weight", the current weight is compared to this value.
1249~1259	41250~41260	Reserved	
User Logic- 4			
1260	41261	User Logic Type	Initial value : 0 ; range 0~5 . 0 : Disable 1 : Delay ON 2 : Delay OFF 3 : Delay ON&OFF 4 : OFF To ON Edge Trigger 5 : ON To OFF Edge Trigger
1261	41262	Logic Trigger Type	Initial value : 0 ; range: 0~64 . Can be selected from the definition of the trigger input port , fixed digital input port1~12 , digital output definition, weight value trigger.
1262	41263	Trigger Function(IN)	Initial value : 0 ; range 0~12 . Select the digital input port 0~12corresponding to this function signal , and input port 0 means that this function is not defined.
1263	41264	Trigger Function(OUT)	Initial value : 0 ; range 0~16 . Select the digital output port0~16 corresponding to the function signal , and the output port- 0 means that the function is not defined.
1264	41265	Delay ON Timer	Initial value : 0 ; range: 0~99.9 .(unit s ) After the trigger signal is valid, the logic output signal is valid after the delay.
1265	41266	Delay Timer OFF	Initial value : 0 ; range: 0~99.9 .(unit s ) After the trigger signal is invalid, the logic output signal will be invalid after the delay.
1266	41267	Output Timer ON	Initial value : 0 ; range: 0~99.9 .(unit s ) The duration after the logic output signal is valid, and becomes invalid after the end of the time.
1267-1268	41268-41269	Logic Trigger Weight	Initial value: 0 , range:0~999999 . When the trigger signal selects "Threshold Weight", the current weight is compared to this value.
1269~1279	41270~41280	Reserved	
User Logic- 5			
1280	41281	User Logic Type	Initial value: 0; range 0~5. 0 : Disable 1 : Delay ON 2 : Delay OFF 3 : Delay ON&OFF 4 : OFF To ON Edge Trigger 5 : ON To OFF Edge Trigger
1281	41282	Logic Trigger Type	Initial value : 0 ; range: 0~64 . Can be selected from the definition of the trigger input port , fixed digital input port1~12 , digital output definition, weight value trigger.
1282	41283	Trigger Function(IN)	Initial value : 0 ; range 0~12 . Select the digital input port 0~12corresponding to this function signal , and input port 0 means that this function is not defined.

1283	41284	Trigger Function(OUT)	Initial value : 0 ; range 0~16 . Select the digital output port0~16 corresponding to the function signal , and the output port- 0 means that the function is not defined.
1284	41285	Delay ON Timer	Initial value : 0 ; range: 0~99.9 .(unit s ) After the trigger signal is valid, the logic output signal is valid after the delay.
1285	41286	Delay Timer OFF	Initial value : 0 ; range: 0~99.9 .(unit s ) After the trigger signal is invalid, the logic output signal will be invalid after the delay.
1286	41287	Output Timer ON	Initial value : 0 ; range: 0~99.9 .(unit s ) The duration after the logic output signal is valid, and becomes invalid after the end of the time.
1287-1288	41288-41289	Logic Trigger Weight	Initialvalue: 0 ; Range: 0~Maximum range. When the trigger signal selects "Threshold Weight", the current weight is compared to this value.
1289~1299	41290~41300	Reserved	
<b>User Logic- 6</b>			
1300	41301	User Logic Type	Initial value: 0; range 0~5. 0 : Disable 1 : Delay ON 2 : Delay OFF 3 : Delay ON&OFF 4 : OFF To ON Edge Trigger 5 : ON To OFF Edge Trigger
1301	41302	Logic Trigger Type	Initial value: 0; range: 0~64. Can be selected from the definition of the trigger input port, fixed digital input port1~12 , digital output definition, weight value trigger.
1302	41303	Trigger Function(IN)	Initial value: 0; range 0~12. Select the digital input port 0~12corresponding to this function signal, and input port 0 means that this function is not defined.
1303	41304	Trigger Function(OUT)	Initial value: 0; range 0~16. Select the digital output port 0~16 corresponding to the function signal, and the output port- 0 means that the function is not defined.
1304	41305	Delay ON Timer	Initial value : 0 ; range: 0~99.9 .(unit s ) After the trigger signal is valid, the logic output signal is valid after the delay.
1305	41306	Delay Timer OFF	Initial value : 0 ; range: 0~99.9 .(unit s ) After the trigger signal is invalid, the logic output signal will be invalid after the delay.
1306	41307	Output Timer ON	Initial value : 0 ; range: 0~99.9 .(unit s ) The duration after the logic output signal is valid, and becomes invalid after the end of the time.
1307-1308	41308-41309	Logic Trigger Weight	Initial value: 0 ; range: 0~999999. When the trigger signal selects "Threshold Weight", the current weight is compared to this value.
1309~1399	41310~41400	Reserved	
<b>Motor parameters - filling mode</b>			
1400	41401	Motor Linker	Initial value: 0 ; Range: 0~4
1401	41402	Filling Mode Gate	Initial value : 0 ; Optional: 0:Air Driven, 1: Step Motor, 2: Motor Driven.
1402	41403	Filler Gate	Initial value: 4.0 ; range: 0~99.9 .(unit s )

		Close Overtime	
1403	41404	Filler Gate Closed Pos.Signal	Initial value: 0 ; Optional: 0 : ON:If Closed ; 1 : OFF: If Closed
1404	41405	Filler Motor Cfg ID	Initial value: 0 , range: 0~4
1405	41406	Filler Motor Frequency	Initialvalue : 12000 , range:1~50000Hz
1406-1407	41407-41408	Motor Steps For Fi-Fill	Initialvalue : 1800 ; range:1~60000 .
1408-1409	41409-41410	Motor Steps For Me-Fill	Initialvalue : 4300 ; range:1~60000 .
1410-1411	41411-41412	Motor Steps For Co-Fill	Initialvalue : 7750 ; range:1~60000 .
1412	41413	DIR Signal Type	Initial value : 0 ; Optional: 0 : Gate Open When Signal OFF ; 1 : Gate Open When Signal ON.
1413	41414	Start Freq in filler motor mode	Initial value : 2000 ; Range: 1~50000Hz (This value should preferably not be greater than the filling motor frequency)
1414	41415	Filler Motor ACC Time	Fill motor acceleration time Initial value: 200 ; Range: 0~9999. (unit s )
1415	41416	Filler Motor DEC Time	Fill motor deceleration time Initial value: 50 ; Range: 0~9999. (in ms )
1416	41417	Co-Fi Gate Time	Initial value: 0.80 ; Range: 0~99.99. (unit s )
1417	41418	Me-Fi Gate Time	Initial value: 0.40 ; Range: 0~99.99 . (unit s )
1418	41419	Fi-Fi Gate Time	Initial value: 0.20 ; Range: 0~99.99 . (unit s )
1419	41420	Clamper Mode	Initial value: 0 ; Optional: 0 : Air Drive 1 : Step Motor Drive 2 : MotorDrive Dual-Limit; 3 : MotorDrive Single-Limit .
1420	41421	Clamper Open Timeout	Initial value: 3.0 ; Range: 0 ~ 99.9 . (unit s )
1421	41422	Clamper Close Timeout	Initial value: 3.0 ; range: 0~99.9 . (unit s )
1422	41423	Clamper Pos. Signal Type	Initial value: 0 ;Optional: 0 : ON:If Closed 1 : OFF:If Closed
1423	41424	Clamper Close Frequency	Initial value: 30000 ; Range: 1~50000Hz .
1424	41425	Clamper Open Frequency	Initial value: 20000 ; range: 1~50000Hz .
1425-1426	41426-41427	Steps For Clamper Close	Initial value: 12000 ; range: 1~60000 .
1427	41428	DIR Signal Type in clamper motor	Initial value: 0 ; Optional: 0 : Lock Bag When Signal Off; 1 : Lock Bag When Signal On.

1428	41429	Start Freq in clamper motor	Initial value: <b>2000</b> ; range: <b>1~50000 Hz</b> . (This value cannot be greater than the pocket frequency)
1429	41430	Clamper Motor ACC Time	Initial value: <b>200</b> ; Range: <b>0~9999</b> . (unit <b>ms</b> )
1430	41431	Clamper Motor DEC Time	Initial value: <b>50</b> ; Range: <b>0~9999</b> (unit <b>ms</b> ) .
1431	41432	Bag Release Time	Initial value: <b>0.5</b> , range: <b>0~99.99</b> . (unit <b>s</b> )
1432	41433	DISC Gate Mode	Initial value: pneumatic mode; <b>0</b> , Air Driven; <b>1</b> . Step Motor <b>2</b> , MotorDrive Single-Limit; <b>3</b> , MotorDrive Dual-Limit; <b>4</b> . Normal Motor Rotating.
1433	41434	DISC Gate Close Overtime	Initial value: <b>3.0</b> ; range: <b>0 ~99.9</b> . (unit <b>s</b> )
1434	41435	DISC Gate Open Overtime	Initial value : <b>3.0</b> ; range: <b>0 ~99.9</b> . (unit <b>s</b> )
1435	41436	DIR Signal Type in DISC motor mode	Initial value: <b>0</b> ; Optional: <b>0</b> .Gate Open When Signal Off. <b>1</b> .Gate Open When Signal On
1436	41437	DISC Gate Pos. Detect	Initial value : <b>0</b> ; <b>0</b> : off ; <b>1</b> : on.
1437	41438	DISC Motor Open Frequency	Initialvalue : <b>30000</b> ;range: <b>1~50000 ( Hz )</b> .
1438	41439	DISC Motor Close Frequency	Initialvalue : <b>20000</b> ;range: <b>1~50000 ( Hz )</b> .
1439-1440	41440-41441	Discharge Steps	Initial value : <b>12000</b> ; range: <b>1~60000</b> .
1441	41442	DISC Motor DR	Initial value : <b>0</b> ; Optional: <b>0</b> : Gate Open When Signal OFF <b>1</b> : Gate Open When Signal ON
1442	41443	DISC Motor Start Frequency	Initial value: <b>2000</b> ; range: <b>1~50000</b>
1443	41444	DISC Motor ACC Time	Initial value: <b>200</b> ; range: <b>0~9999</b>
1444	41445	DISC Motor DEC Time	Initial value: <b>50</b> ; range: <b>0~9999</b>
1445	41446	DISC Gate Open Timer	Initial value: <b>1.00</b> ; range: <b>0~99.99</b>
1446	41447	Filling motor Power-ON Go 0 Pos. Freq	Initial value: <b>20000</b> ; range: <b>0~50000</b>
1447	41448	Clamper motor Power-ON Go 0 Pos. Freq	Initialvalue: <b>20000</b> ; range: <b>0~50000</b>
1448	41449	DISC motor Power-ON Go 0 Pos. Freq	Initial value: <b>20000</b> ; range: <b>0~50000</b>
1449	41450	NO Position Signal For Fill Gate	initial value: <b>0</b> <b>0</b> : Filling use inplace signal <b>1</b> : Filling don't use inplace signal

1450	41451	NO Position Signal For Clamper	initial value: 0 0: Clip/loose bag use inplace signal 1: Clip/loose bag don't use inplace signal
1451	41452	NO Position Signal For DISC Gate	initial value: 0 0: Discharge close door use inplace signal 1: Discharge close door don't use inplace signal
1452-1453	41453-41454	Motor Steps For Closed	initial value: 100; range: 1~60000.
1454-1455	41455-41456	Steps For Clamper Open	initial value: 100; range: 1~60000.
1456-1457	41457-41458	Discharge Steps For Closed	initial value: 100; range: 1~60000.
1458-1499	41459-41500	Reserved	
1500	41501	Slider mode	Fixed as a stepper motor after activation;
1501	41502	Slider Backward Timeout	initial value: 5.0; range: 0~99.9s
1502	41503	Slider Pos.Signal Type	initial value: 0; optional: 0: Signal valid inplace; 1: Signal invalid inplace.
1503	41504	Slider Forward Frequency	initial value: 30000; range: 1~50000Hz.
1504	41505	Slider Backward Frequency	initial value:20000; range:1~50000Hz.
1505-1506	41506-41507	Steps For Slider Forward	initial value: 12000; range: 1~60000.
1507	41508	DIR Signal Type	initial value: 0; optional: 0: Forward When Signal Off; 1: Forward When Signal On.
1508	41509	Start Freq	initial value: 2000; range: 0~50000Hz. (this value can't bigger than clamper close frequency)
1509	41510	ACC Time	initial value: 200; range: 0~9999. (unit: ms)
1510	41511	DEC Time	initial value: 50; range: 0~9999 (unit: ms) .
1511	41512	Power-ON Go 0 Pos.Freq	initial value: 2000; range: 1~50000(Hz).
1512	41513	Clamping Arm Lock Mode	initial value: air mode; 0: air mode; 1: Step motor arm lock clip bag ;
1513	41514	UnClamping Arm Timeout	initial value: 3.0s; range: 0~99.9s.
1514	41515	Clamping Arm Pos.Signal Type	initial value: 0; optional: 0.ON;if in Close 1. OFF;if in Close.
1515	41516	Clamping Arm Lock Frequency	initial value: 30000; range: 1~50000(Hz).
1516	41517	UnClamping Arm Lock Frequency	initial value: 20000; range: 1~50000(Hz).
1517-1518	41518-41519	Steps For Clamping Arm Lock	initial value: 12000; range: 1~60000.
1519	41520	DIR Signal Type	initial value: 0; optional: 0: Lock Bag When Signal Off. 1: Lock Bag When Signal ON.

1520	41521	Start Freq	initial value: 2000; range: 1~50000(Hz).
1521	41522	ACC Time	initial value: 200; range: 0~9999. (ms)
1522	41523	DEC Time	initial value: 50; range: 0~9999. (ms)
1523	41524	Power-ON Go 0 Pos.Freq	initial value: 2000; range: 1~50000(Hz).
1524	41525	Tractor mode	initial value: 0: Disable; optional: 0: Disable; 1: BUILT-IN tractor
1525	41526	Slider Forward Predelay	default value: 0, range: 0.0~99.9s.
1526	41527	Slider Backward Predelay	default value: 0, range: 0.0~99.9s.
1527	41528	Clamping Arm Lock Predelay	default value: 0, range: 0.0~99.9s.
1528	41529	Clamping Arm Backward Delay	default value: 0, range: 0.0~99.9s.
1529	41530	Stretching Bags Predelay	default value: 0, range: 0.0~99.9s.
1530	41531	Unstretching Bags Predelay	default value: 0, range: 0.0~99.9s.
1531~1599	41532~41600	Reserved	
<b>Communication parameters - serial port 2 parameters (RS485)</b>			
1600	41601	Slave COM ID	Initial value: 1; 1~9 9 optional.
1601	41602	Protocol	0 : Modbus-RTU ; 1 : Print 2 : Self-Sending mode 3:Modbus_8802S-P; 4: Re-Cont
1602	41603	Baudrate	0 : 9600 1 : 19200 2 : 38400 3 : 57600 4 : 115200
1603	41604	Data Format	Communication data format selection (data bit, parity bit, stop bit. E : even parity; N : no parity ) 0 : 8-E-1 1 : 8-N-1 2 : 7-E-1 3 : 7-N-1
1604	41605	Dword Format	Initial value : 0 : Range : 0-1 0 : AB-CD; 1: CD-AB.
<b>Communication parameters - serial port 1 parameters (RS232)</b>			
1605	41606	Slave COM ID	Initial value: 1; 1~9 9 optional.
1606	41607	Protocol	0 : Modbus-RTU ; 1 : Print 2 : Self-Sending mode 3:Modbus_8802S-P; 4: Re-Cont
1607	41608	Baudrate	0 : 9600 1 : 19200 2 : 38400 3 : 57600 4 : 115200

1608	41609	Data Format	Communication data format selection (data bit, parity bit, stop bit. E : even parity; N : no parity ) 0 : 8-E-1 1 : 8-N-1 2 : 7-E-1 3 : 7-N-1
1609	41610	Dword Format	Initial value : 0 : Range : 0-1 0 : AB-CD;1: CD-AB.
<b>Communication parameters – Ethernet Config parameters</b>			
1610	41611	Modbus-TCP Dword Format	Initial value : 0 : Range : 0-1 0 : AB-CD;1: CD-AB.
1611	41612	Server Port	Initial value: 502 ; Range: 1 ~ 65535
1612	41613	IP	Initial value: 192.168.101. 246. Range: 0 ~ 255.
1613	41614		
1614	41615		
1615	41616		
1616~1699	41617~41700	Reserved	
<b>I/O Module custom parameters</b>			
1700	41701	Input port 1 definition	Write the corresponding value of the function.If the input port 3 is defined as running, write 1 at address 41703 (refer to 4.8.1 output and input definition table for numeric function code) Read: return the current switching value custom state
1701	41702	Input port 2 definition	
1702	41703	Input port 3 definition	
1703	41704	Input port 4 definition	
1704	41705	Input port 5 definition	
1705	41706	Input port 6 definition	
1706	41707	Input port 7 definition	
1707	41708	Input port 8 definition	
1708	41709	Input port 9 definition	
1709	41710	Input port 10 definition	
1710	41711	Input port 11 definition	
1711	41712	Input port 12 definition	
1712	41713	Output port 1 definition	Write the corresponding value of the function.If the output port 3 is defined as running, write 1 at address 41715 (refer to 4.8.1 output and input definition table for numeric function code).
1713	41714	Output port 2 definition	
1714	41715	Output port 3 definition	
1715	41716	Output port 4 definition	
1716	41717	Output port 5 definition	
1717	41718	Output port 6 definition	
1718	41719	Output port 7 definition	
1719	41720	Output port 8 definition	
1720	41721	Output port 9 definition	
1721	41722	Output port 10 definition	
1722	41723	Output port 11 definition	
1723	41724	Output port 12 definition	
1724	41725	Output port 13 definition	
1725	41726	Output port 14 definition	
1726	41727	Output port 15 definition	
1727	41728	Output port 16 definition	

1728	41729	Start / end ON/OFF test	write: The stop state can be written. Write <b>1</b> to start the ON/OFF test. Write <b>0</b> to exit the ON/OFF test state.
1729	41730	Input test	Write: not allowed to write Read: From the low to the high, the corresponding port <b>IN1~12</b> input. <b>1</b> is valid for input, <b>0</b> is invalid for input.
1730-1731	41731-41732	Output test	Write: The ON/OFF test ON/OFF can be written in the open state, and the output from the low to the high port corresponds to the port <b>OUT1~16</b> . <b>1</b> is valid for output, <b>0</b> is invalid for output. Read: Returns the status of the current output ON/OFF port, from the low to the high, respectively, corresponding to the port <b>OUT1~16</b> output. <b>1</b> is valid for output, <b>0</b> is invalid for output.
1732~1799	41733~41800	Reserved	
<b>Other parameter settings</b>			
1800	41801	Print Total ACUM	Read as <b>0</b> Write <b>1</b> , Print Total ACUM
1801	41802	Print recipe ACUM	Read as <b>0</b> Write <b>100</b> to print the current recipe ACUM Write <b>1-20</b> , print the corresponding formula ACUM Write <b>101</b> to Print All Recipe ACUM
1802	41803	Print user ACUM	Read as <b>0</b> Write <b>100</b> to Print Choose User ACUM Write <b>0-9</b> , print the corresponding user ACUM Write <b>101</b> , Print All User ACUM
1803	41804	Reset	<b>8800</b> Reset All(Including Calibration) <b>8801</b> Reset All(Except Calibration) <b>8802</b> Reset Recipe Parameter <b>8803</b> Reset Maintenance Paramter <b>8804</b> Reset Peripherals Parameter <b>8805</b> Reset Motor Config Parameter <b>8806</b> Reset Calibration Parameter <b>8807</b> Reset I/O Function Module <b>8808</b> Reset User Logic Parameter <b>8809</b> Reset communicate parameter
1804	41805	Backup	<b>Read:</b> 0: No Backup Data; 1: Have Backup Data. <b>Write:</b> Write <b>9900</b> to Execute Parameter Backup; Write <b>9901</b> to Execute Recovery From Backup Write <b>9902</b> to p Execute Delete Backup.
1805-1806	41806-41807	Backup date	Read only
1807-1808	41808-41809	Backup time	
1809	41810	year	<b>0-99</b>
1810	41811	month	<b>1-12</b>
1811	41812	day	<b>1-31</b>
1812	41813	Time	<b>0-23</b>
1813	41814	Minute	<b>0-59</b>
1814	41815	second	<b>0-59</b>
1815	41816	Clear All Recipes ACUM	Write <b>1</b> clear total accumulation



1816	41817	Clear recipe ACUM	Write <b>1-20</b> to clear the Recipe ID ACUM; Write <b>100</b> to Clear Choose Recipe ACUM; Write <b>101</b> to Clear All Recipe ACUM.
1817	41818	Clear user ACUM	Read as <b>0</b> . Write <b>0-9</b> to clear the user ID ACUM ; Write <b>100</b> to clear choose user ACUM ; Write <b>101</b> to clears all user ACUM.
1818	41819	User ID	Read out current ID, parameter ready only
1819-1949	41820-41950	Reserved	
<b>Batch setting</b>			
1950	41951	Batch	Initial value: <b>0</b> ; range: <b>0-9999</b> .
1951	41952	Remain PCS	Read only
1952~1999	41953~42000	Reserved	
Formula target value (reserved 2000~2300 )			
2000-2001	42001-42002	Recipe <b>1</b> target	Initial value: <b>0</b> .
2002-2003	42003-42004	Recipe <b>2</b> target	Initial value: <b>0</b> .
.....		.....	Initial value: <b>0</b> .
2038-2039	42039-42040	Recipe <b>20</b> target	Initial value: <b>0</b> .
<b>Cumulative weight</b>			
2040-2041	42041-42042	Total cumulative weight is 6 digits	
2042-2043	42043-42044	The total cumulative weight low <b>9</b>	
2044-2045	42045-42046	Total accumulated number of packets	
2046-2047	42047-42048	Formula <b>1</b> cumulative weight is 6 digits high	
2048-2049	42049-42050	Formulation <b>1</b> cumulative weight low <b>9</b>	
2050-2051	42051-42052	Formula <b>1</b> cumulative count	
.....		.....	
2160-2161	42161-42162	Formulation <b>6</b> High <b>20</b> cumulative weight	
2162-2163	42163-42164	Formulation <b>20</b> cumulative weight low <b>9</b>	
2164-2165	42165-42166	Formula <b>20</b> cumulative times	
<b>User cumulative weight and number of times</b>			
2166-2167	42167-42168	User <b>0</b> cumulative weight is 6 digits high	
2168-2169	42169-42170	User <b>0</b> cumulative weight is 9 digits lower	
2170-2171	42171-42172	User <b>0</b> cumulative times	
2172-2173	42173-42174	User <b>1</b> cumulative weight is 6 digits high	
2174-2175	42175-42176	User <b>1</b> cumulative weight is 9 digits lower	
2176-2177	42177-42178	User <b>1</b> cumulative times	
2178-2179	42179-42180	User <b>2</b> cumulative weight is 6 digits high	
2180-2181	42181-42182	User <b>2</b> cumulative weight is 9 digits lower	
2182-2183	42183-42184	User <b>2</b> cumulative times	
2184-2185	42185-42186	User <b>3</b> cumulative weight is 6 digits high	
2186-2187	42187-42188	User <b>3</b> cumulative weight is 9 digits lower	
2188-2189	42189-42190	User <b>3</b> cumulative times	
2190-2191	42191-42192	User <b>4</b> cumulative weight is 6 digits high	
2192-2193	42193-42194	User <b>4</b> cumulative weight is 9 digits lower	
2194-2195	42195-42196	User <b>4</b> cumulative times	
2196-2197	42197-42198	User <b>5</b> cumulative weight is 6 digits high	
2198-2199	42199-42200	User <b>5</b> cumulative weight is 9 digits lower	
2200-2201	42201-42202	User <b>5</b> cumulative times	
2202-2203	42203-42204	User <b>6</b> cumulative weight is 6 digits high	
2204-2205	42205-42206	User <b>6</b> cumulative weight is 9 digits lower	
2206-2207	42207-42208	User <b>6</b> cumulative times	
2208-2209	42209-42210	User <b>7</b> cumulative weight is 6 digits high	
2210-2211	42211-42212	User <b>7</b> cumulative weight is 9 digits lower	

2212-2213	42213-42214	User 7 cumulative times	
2214-2215	42215-42216	User 8 cumulative weight is 6 digits high	
2216-2217	42217-42218	User 8 cumulative weight is 9 digits lower	
2218-2219	42219-42220	User 8 cumulative times	
2220-2221	42221-42222	User 9 cumulative weight is 6 digits high	
2222-2223	42223-42224	User 9 cumulative weight is 9 digits lower	
2224-2225	42225-42226	User 9 cumulative times	
2226~2299	42227~42300	Reserved	
<b>Compile information ( reserved 9000~9100)</b>			
9000-9001	49001-49002	Logic Version	For example : 0 1000 0
9002-9003	49003-49004	Logic Compile Date	For example : 161201
9004-9005	49005-49006	Logic Compile Time	For example : 130805
9006-9007	49007-49008	IO Board Version	For example : 100
9008~9099	49009~49100	Reserved	
<b>Coil address (reserved 0~100 )</b>			
0	00001	Start	Write 1 to execute the operation Read as 0
1	00002	Emergency stop	
2	00003	Stop	
3	00004	Pause	
4	00005	Zeroing	
5	00006	Clear Alarm	
6	00007	Lock/Unlock Request	
7	00008	Change Recipe	
8	00009	Manual Fine Flow	
9	00010	Manual Coarse Flow	
10	00011	Manual Discharge	
11	00012	Manual Empty Material	
12	00013	Hanging bag	
13	00014	Sewing Input	
14	00015	Sewing E-Stop	
15	00016	Aux. Pulse 1	
16	00017	Aux. Pulse 2	
17	00018	Aux. Pulse 3	
18	00019	Aux. Pulse 4	
19	00020	Clear For Adaptive	
20	00021	Manual Medium Flow	This address can only be written to 1. Read 1 is valid, 0 is invalid.
21	00022	Manual Flow(Only for material Calibration)	This address can only be written to 1. Read 1 is valid, 0 is invalid.
22	00023	Manual Discharge(Only for material Calibration)	This address can only be written to 1. Read 1 is valid, 0 is invalid.
23	00024	Reserved	
24	00025	IN1(Read By COM)	
25	00026	IN2(Read By COM)	
26	00027	IN3(Read By COM)	
27	00028	IN4(Read By COM)	
28	00029	IN5(Read By COM)	
29	00030	No Level Detection	
30	00031	Manual End	
...	...	Reserved	

80	00081	Clear Choose user ACUM	Write 1 to execute the operation All readings are 0
81	00082	Clear all users ACUM	
82	00083	Clear Choose Repice ACUM	
83	00084	Clear all Repice ACUM	
84	00085	Clear Total ACUM	
...	...	Reserved	
100	00101	Reset All	Write 1 to perform the corresponding reset operation Read as 0. Can be written at runtime but does not take effect, needs to stop running to write to be effective.
101	00102	Reset Calibration	
102	00103	Reset Weight Parameter	
103	00104	Reset Recipe Parameter	
104	00105	Reset Peripherals Parameter	
105	00106	Reset I/O Function	
106	00107	Reset Motor Parameter	
107	00108	Reset User Logic Parameter	
108	00109	Execute Parameter Backup	
109	00110	Execute Recovery From Backup	
110	00111	Execute Delete Backup	Write 1 to delete backup parameters. Read: 1 has backup parameters; 0 is no backup parameter.
111	00112	Reset communication parameter	Write 1 to perform the corresponding reset operation All readings are 0. Can be written at runtime but does not take effect, needs to stop running to write to be effective.
<b>IO Testcoil address</b>			
150	00151	IO test switch:	Write 1 to turn on the switch value test switch, read: 0 to turn off the test switch
151	00152	Input port 1	Not effective when written. When the input port is valid, the corresponding address is read as 1 When the input port is invalid, the corresponding address is read as 0
152	00153	Input port 2	
153	00154	Input port 3	
154	00155	Input port 4	
155	00156	Input port 5	
156	00157	Input port 6	
157	00158	Input port 7	
158	00159	Input port 8	
159	00160	Input port 9	
160	00161	Input port 10	
161	00162	Input port 11	
162	00163	Input port 12	
163	00164	Output port 1	When writing 1, the output port corresponding to the address should be valid
164	00165	Output port 2	
165	00166	Output port 3	
166	00167	Output port 4	
167	00168	Output port 5	
168	00169	Output port 6	
169	00170	Output port 7	
170	00171	Output port 8	
171	00172	Output port 9	
172	00173	Output port 10	
173	00174	Output port 11	
174	00175	Output port 12	
175	00176	Output port 13	

<b>176</b>	<b>00177</b>	Output port 14
<b>177</b>	<b>00178</b>	Output port 15
<b>178</b>	<b>00179</b>	Output port 16

Note : The controller will perform the weightless gain calibration according to the currently stored load cell power supply voltage, load cell sensitivity, and load cell maximum range (where the maximum range input cannot be greater than the maximum range set in the controller calibration (modbus addresses 10104 and 40105).

Calibration principle:

Zero calibration: Zero calibration can be performed via modbus (40106 and 40107) addresses. (If you skip the zero calibration and directly perform the weightless gain calibration, the last recorded zero will be used as the current zero calibration)

Gain calibration: Gain millivolts is the input load cell power multiplied by the load cell sensitivity, and the gain weight is the load cell's maximum range. The gain millivolts and gain weight used for gain scaling here are referenced below.

The first type of weightless gain calibration method: when the load cell power supply (5000mv) is input separately, the weightless calibration operation will be directly performed.

The second type of weightless gain calibration method: input load cell sensitivity (2mv/v) and input the load cell's maximum range (1000kg) will carry out the weightless calibration operation (note here, please input only the load cell sensitivity or only input the maximum range. When the range is measured, the entered value is not saved immediately. Only when both values are entered and the two values entered are reasonable, the data is saved and then the gain calibration is performed.

## 7. Automatic bagging process

The GM9907 bagging controller automatically controls the entire bagging process of coarse, medium and fine filling and discharging in the automatic bagging state. Supports a variety of modes including net weigher, gross weigher, jumbo bag, valve scale and PLC mode. The scale structure and working mode are selected in the maintenance parameters.

### 7.1 Net Weigher Scale

In this mode, the material is fed from the preparation hopper to the measuring hopper through the filling mechanism (coarse, medium and fine), and the weight sampling of the controlling control process is completed in the measuring hopper (the weighing load cell is mounted on the measuring hopper). After the controlling is completed, the material is discharged into the package through the unloading mechanism on the measuring hopper. Its structure is shown in the following figure:

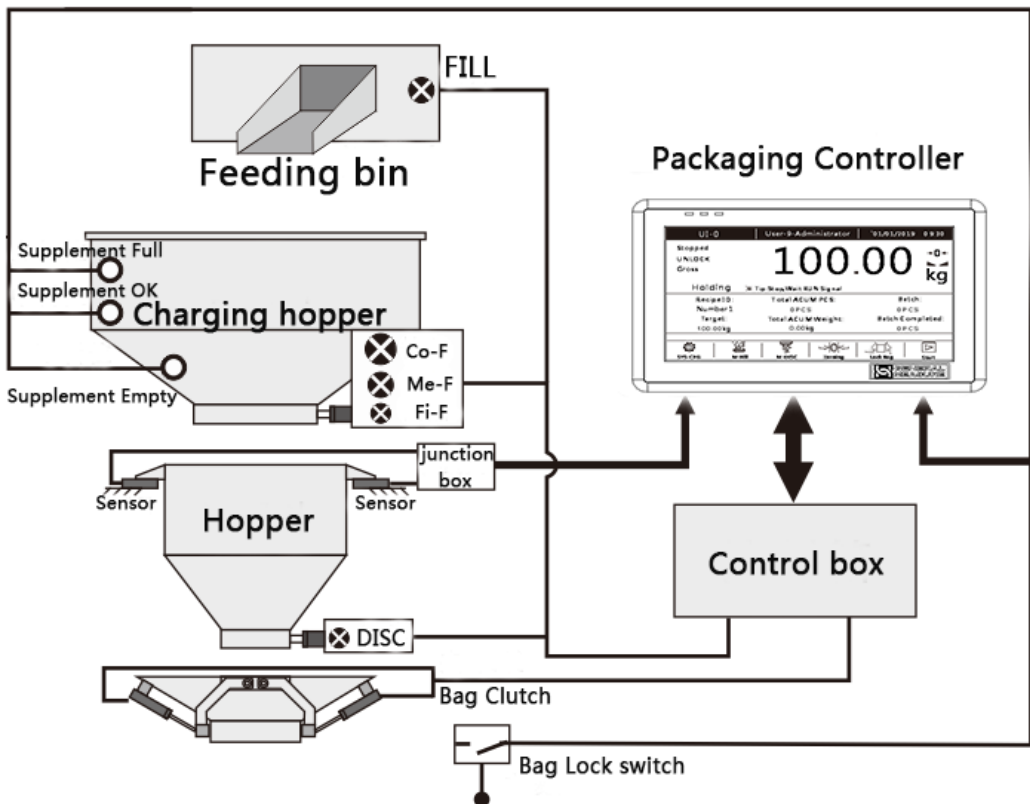

**Basic process description:**

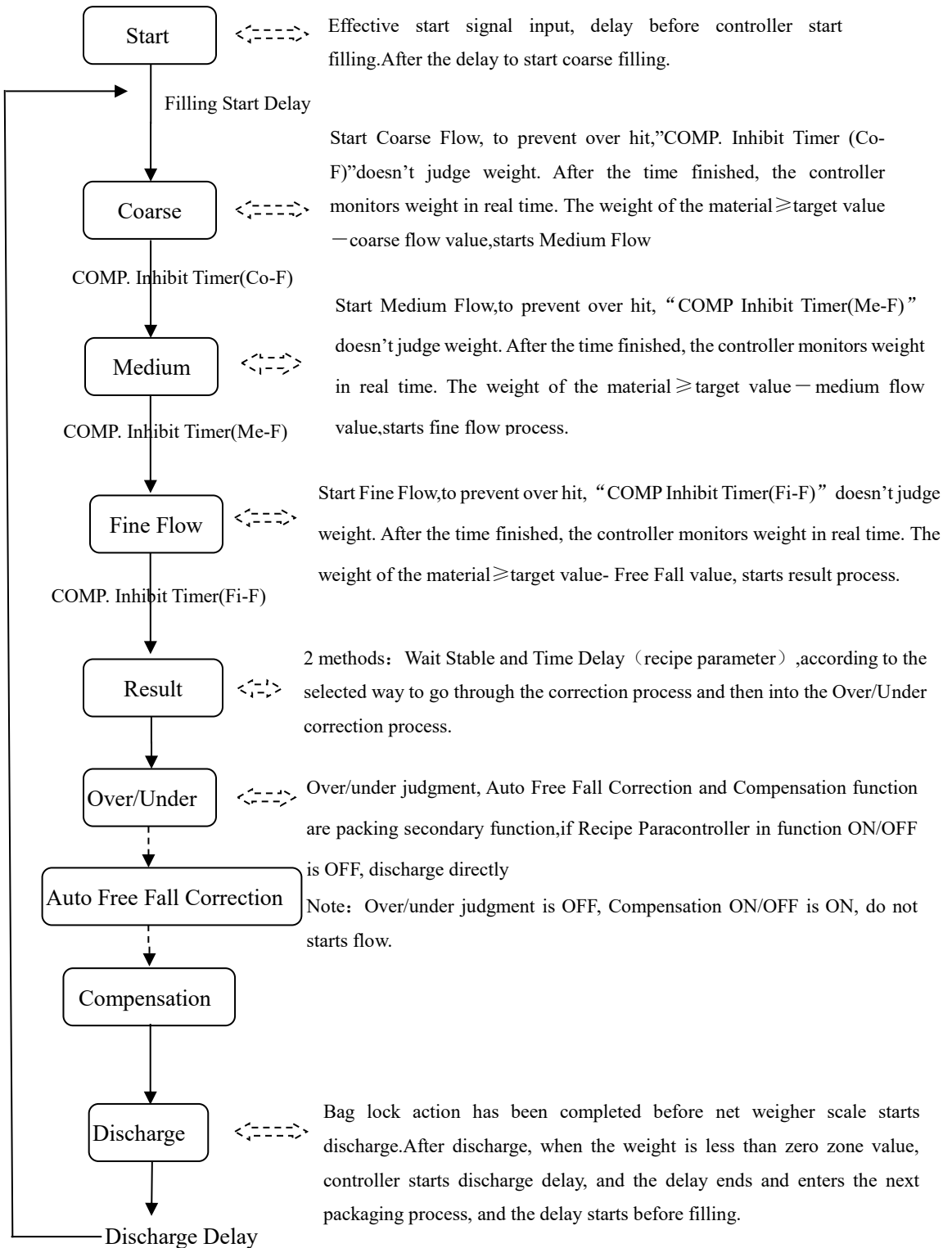

## 7.2 Gross Weigher Scale

In this mode, the material is directly fed into the package from the hopper through the filling mechanism (coarse, medium, and fine), and the weight sampling of the controlling control process is completed in the package (the weighing load cell is mounted on the hopper). After the controlling is completed, the controller controls the unlock bag directly. Its structure is shown in the following figure:

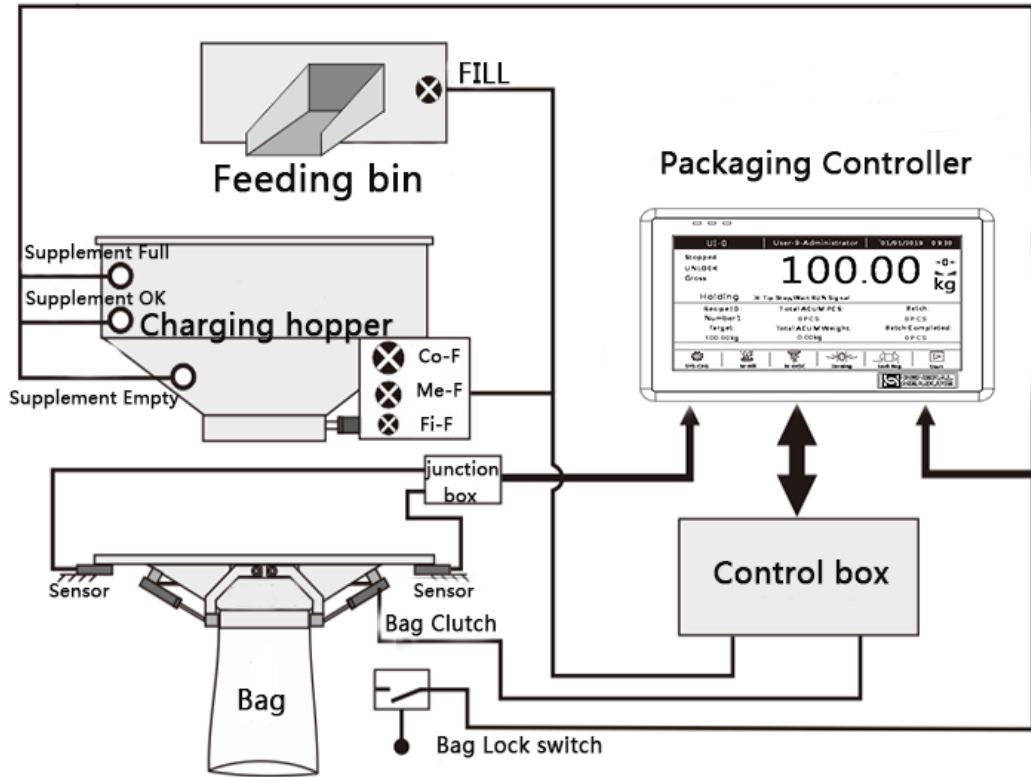

The difference between the net weigher packing process and the gross weigher packing process is that the load cell is installed on the hopper. After starting, it is necessary to complete the bag clamping action before starting the filling delay and starting the filling process.

**Basic process description:**

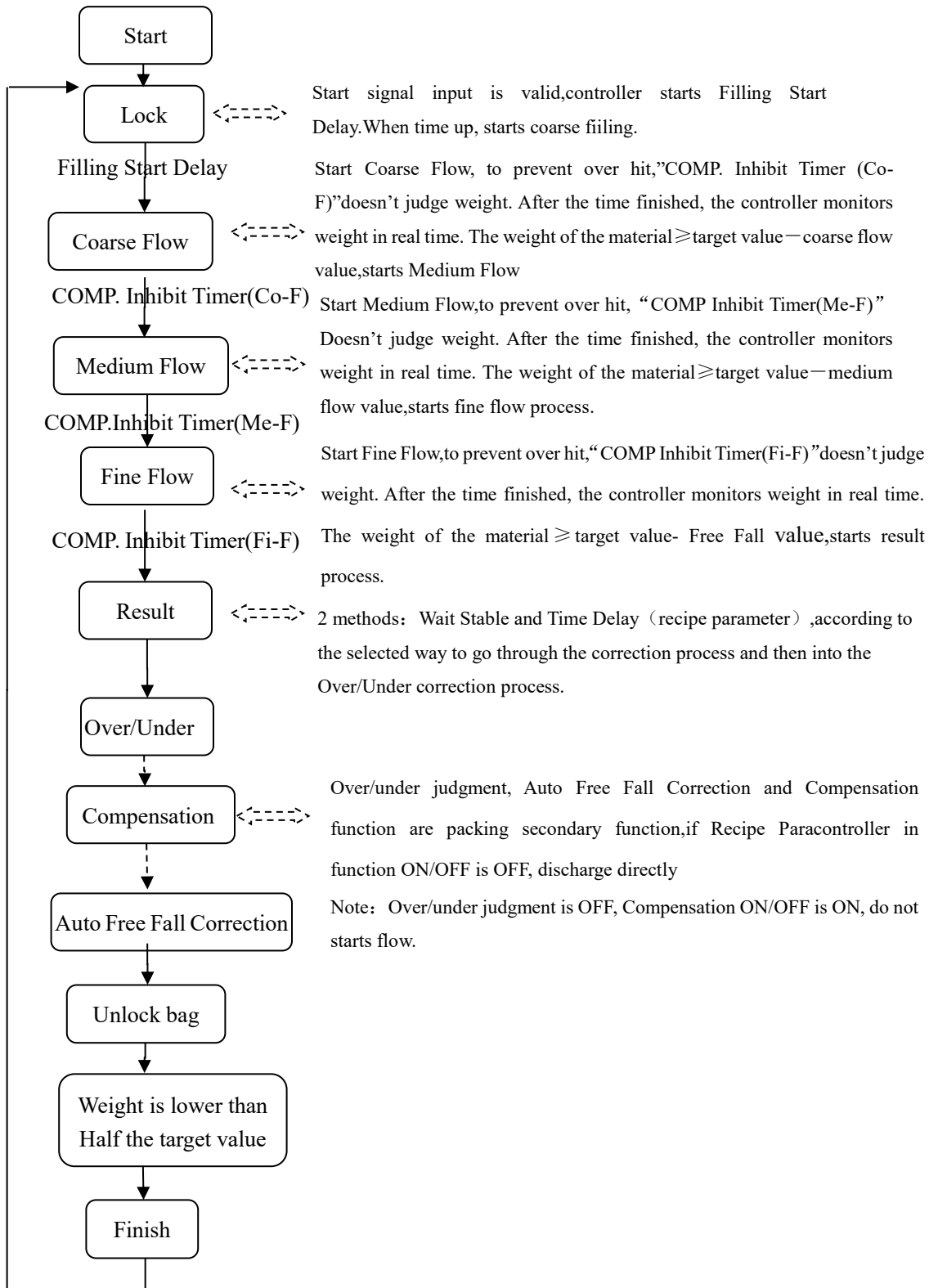



### 7.3 Jumbo bag scale

**Process description:**

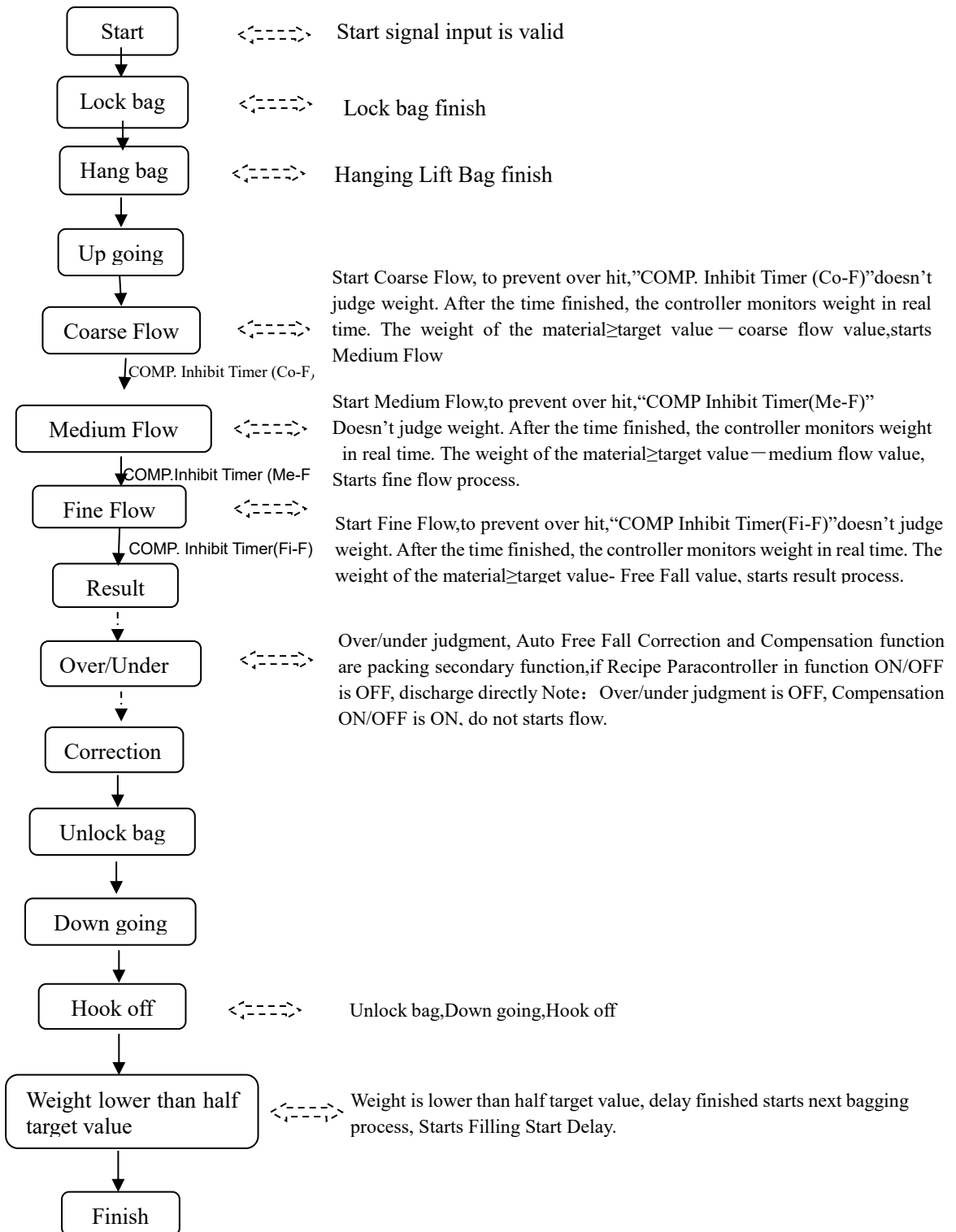

## 7.4 Valve port scale

### Process description:

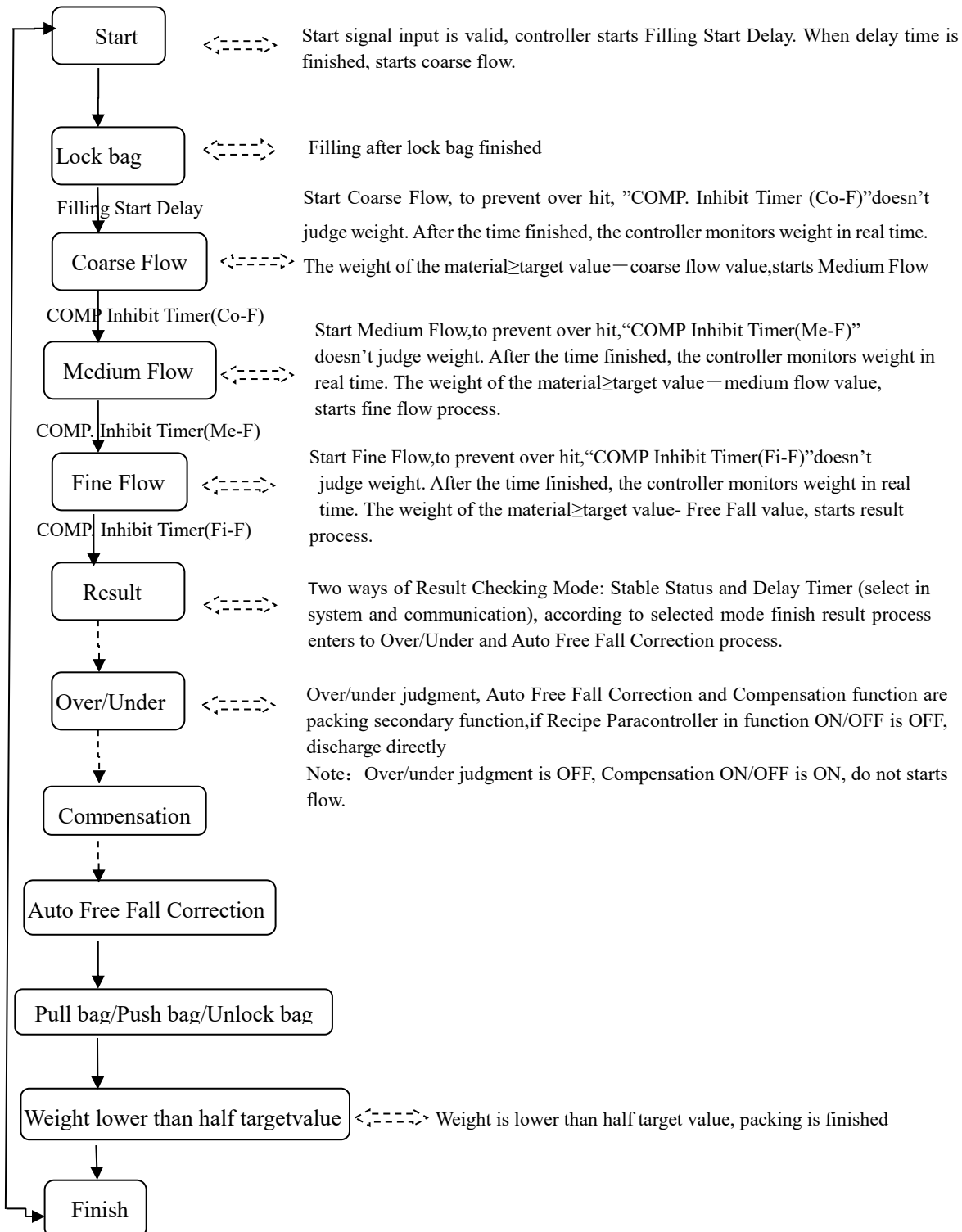

## 7.5 PLC mode

In the PLC mode, the status displayed on the main page of the controller is changed to: coarse add, medium add, fine add, over tolerance, undershoot, upper limit, lower limit, zero zone.

When the weighing process starts, the quick addition, medium addition, and fine addition output are effective, and the main interface displays the coarse addition, medium addition, and fine addition in sequence.

When the weighing value > target value + excess value, the out-of-tolerance output is valid.

The under output is valid when the weighing value < target value - underbalance value.

When the weighing value > upper limit value, the upper limit output is valid.

When the weighing value < lower limit, the lower limit output is valid.

When the weighing value < zero zone value, the zero zone output is valid.

## 7.6 Double scale interlocking bagging mode

The two controllers can be combined into two pairs of buckets and double bucketless scales by setting and wiring. The two measuring buckets can be weighed at the same time and connected to the same pocket mechanism. The two scales can be fed at the same time to improve the bagging speed. Setting 2 aspects, the working mode of the controller system and the communication parameter scale body structure are two controllers:

interlocking **A** scale and interlocking **B** scale. **Note: The pockets are delayed by two controllers to be set the same.** Its structure is shown in the following figure:

Refer to the following figure for ON/OFFing wiring:

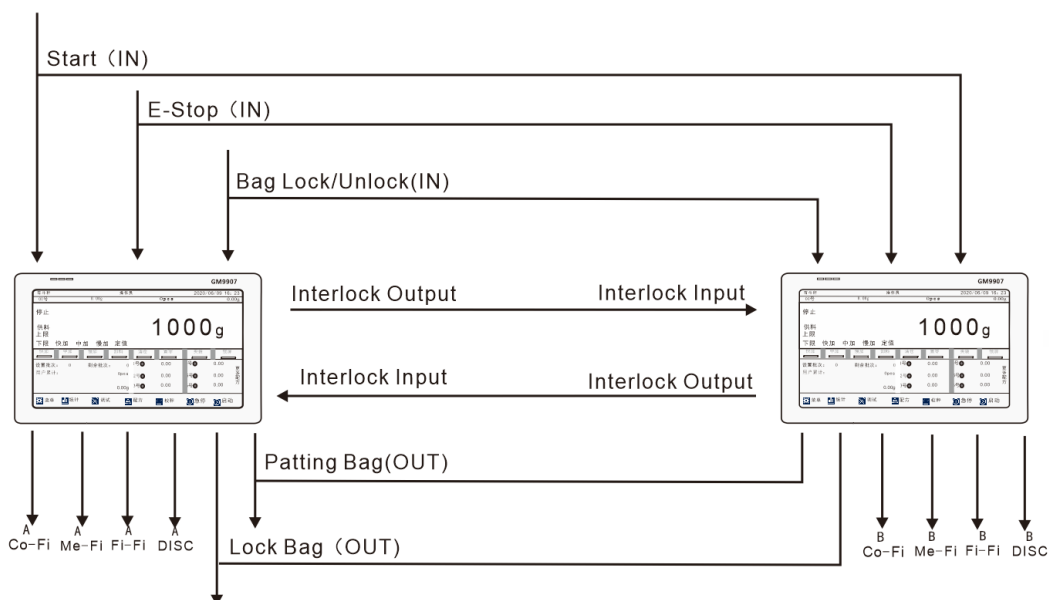

If the scale body mode selects the double bucket scale interlock mode, the target values of the **A** scale and the **B** scale should be set separately, the Co-Fi value, the Me-Fi value, and the Fi-Fi value, and the materials are separately measured from the storage hopper through the two filling mechanisms. Filling in the bucket (coarse, medium and fine filling), under the operating state, it can independently control the filling speed of **A** scale and **B** scale, the whole bagging process of unloading and automatic unlock bag. The **A** and **B** scales are first quantitatively completed before the unloading process.

- Lock bag

**Net Weigher:** A scale or B scale, first judge the pocket signal before discharging, start the pocket delay when the pocket signal is valid, the mechanism clamps the bag after the delay is over, and then starts the unloading action, who is A and B scale First, quantify who will discharge first. If one is discharging scale, the other scale even quantitatively complete, also need to wait for the next bag-scale signal is valid before unloading.

**Gross Weigher:** judge the pocket signal before filling. When the pocket signal is valid, both scales start the pocket delay. After the delay, the mechanism clamps the bag. After the bag is completed, the delay before filling is started to avoid leakage of materials. After the delay time of the bag is reached, the controller judges the stability, peels after stabilization, and the weight of the bag is used as the tare weight. Then the controller changes from the gross weight state to the net weight state and starts the filling process.

● **Unlock bag**

**Net Weigher:** the controller judges whether the material in the A scale or the B scale hopper is lower than the near zero value. If it is lower, the timer discharge delay is started. After the delay time is reached, the controller closes the unloading and starts the unlock bag delay. The unlock bag is automatically released after the delay of the unlock bag.

**Gross Weigher:** Start the unlock bag start delay after the setting, and automatically release the bag after the delay. (If there is a bag patting function, start the unlock bag start delay after the bag is finished). The controller controls the conveyor signal output and starts the conveyor.

### 7.7 Binyes Multi-scale mode

**Basic process description:**

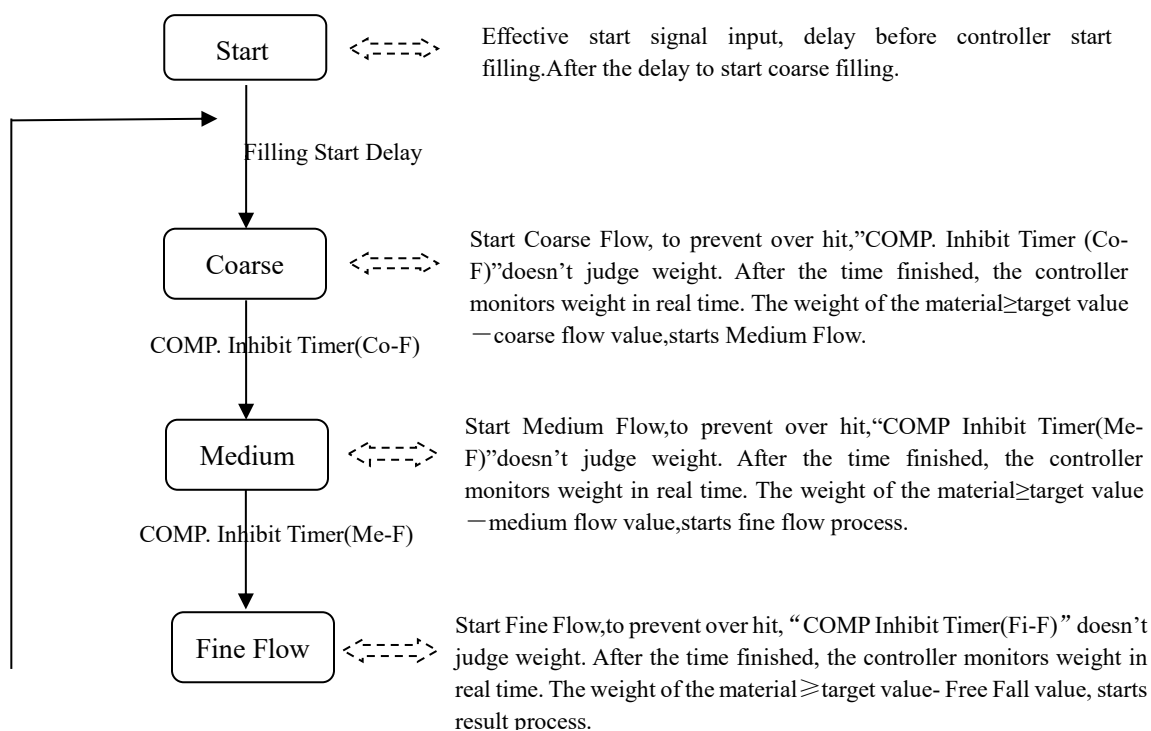

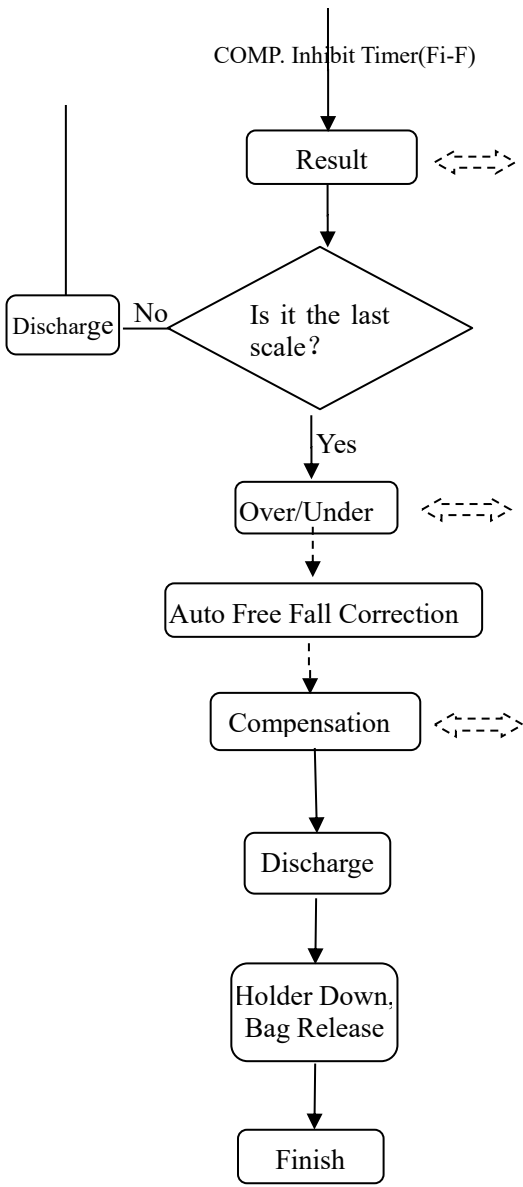

2 methods: Wait Stable and Time Delay (recipe parameter), according to the selected way to go through the correction process and then into the Over/Under correction process.

Over/under judgment, Auto Free Fall Correction and Compensation function are packing secondary function, if Recipe Paracontroller in function ON/OFF is OFF, discharge directly  
 Note: Over/under judgment is OFF, Compensation ON/OFF is ON, do not start flow.

Bag lock action has been completed before net weigher scale starts discharge. After discharge, when the weight is less than zero zone value, controller starts discharge delay, and the delay ends and enters the next packaging process, and the delay starts before filling.

## 8. Motor working process

### 8.1 Motor filling section

#### 8.1.1 Stepper motor filling

Stepper motor mode control fill door open/close: The IO involved is: **O19**(Filler Gate PWM) / **O20**(Filler Gate DIR), **I23**(Filler Gate Closed Pos.), I23 is determined by the type of DIR signal type.

Take the process of coarse filling and fine adding as an example:

- **Coarse filling process:** controller control **O20**(Filler Gate DIR) output, to ensure that the motor rotation direction is the door opening direction, then **O19**(Filler Gate PWM) according to the set **filling motor frequency** to output pulses, control the filling stepper motor to turn in the door opening direction, (**When the number of filling pulse output** reaches the set value, the output pulse signal is stopped, and the filling door stops rotating. At this time, it is in the coarse-adding state. Then the controller changes (**motor rotation direction signal**) output to the door closing direction.
- **Medium filling process:** **O19**(Filler Gate PWM) according to the set **filling motor frequency** to output pulses, control the filling stepper motor to turn in the closing direction, Number of the filling pulse reaches the set value and stops outputting the pulse signal, the filling gate Stop turning, this time is in the middle state.
- **Fine filling process:** **O19**(Filler Gate PWM) according to the set **fill motor frequency** to output pulses, control filling stepper motor continues to turn in the closing direction, (**fill pulse output**) number reaches the set value and then stop output pulse signal, filling door stops rotating, in this case the fine fill state.
- **Filling off:** **O19**(Filler Gate PWM) According to the set **filling motor frequency** , the pulse is output, and the filling stepping motor continues to rotate in the closing direction until the detection **I23**(Filler Gate Closed Pos.). The input pulse is stopped after the input is valid, and the filling gate stops. Rotate, at this point the fill is completely closed.

Note: If the closing process time exceeds the **filling door closing timeout time** set by the filling closing timeout time, the controller has not detected (**the filling door is closed in place**), then the controller will stop filler gate PWM output , and the alarm **filling will close the timeout** .

#### 8.1.2 Ordinary motor filling

Ordinary motor mode control fill door switch: The I/O Module involved is:**O25**(Filler Open) / **O26**(Filler Close) , **I23**(Filler Gate Closed Pos.).

Take the process of coarse filling and fine adding as an example:

Take the process of coarse filling and fine adding as an example:

- **Coarse filling process:** The filling process starts after the delay time. The controller first makes the **O25**(Filler Open) signal output valid, the effective time is the coarse opening time , and the coarse filling process begins.
- **Medium filling process:** When the weight of the material in the hopper  $\geq$  the

single scale target value - coarse increase the advance amount, the signal output **O26**(Filler Close) is valid, and the effective time is "coarse opening time - medium opening time".

- **Fine filling process:** When the material weight in the hopper  $\geq$  single scale target value - medium advance amount, the **O26**(Filler Close) signal output is valid, the effective time is "medium plus door opening time - fine plus door opening time"

- **Filling off:** When the material weight in the hopper  $\geq$  single scale target value - fine plus advance, the **O26**(Filler Close) signal output is valid until the **fill door in-position signal is detected I23**(Filler Gate Closed Pos.) output.

## 8.2 Motor clamper bag part

### 8.2.1 Step motor clamper bag

Stepper motor mode control clamper bag: The IO quantity involved is: **O21**(Clamper PWM) / **O22**(Clamper DIR) / **I25**(Bag Released), I25 is determined by the type of loose bag DIR signal type.

Take the process of clamping /releasing bag in the net weigher mode as an example:

- **Clamper bag process:** the controller control **O22**(Clamper DIR) output, to ensure that the motor rotation direction is the bag direction, and then **O21**(Clamper PWM) output according to the set clamper close frequency to output pulses, control clamping /releasing bag stepping motor rotates in the direction of the pocket, and stop outputting pulse signals when the number of pulses required for bag clamping reaches the set number. At this time, the pocket mechanism is in the clamper bag state. Then the controller changes **O22**(Clamper DIR) and the output is in the direction of the release bag.

- **Release bag process:** **O21**(Clamper PWM) output according to the set clamper open frequency to output pulses, control the bag loosening stepper motor to rotate in the direction of the bag loosening, until the detection **I25**(Bag Released) input is valid, stop output pulse signal In this case the bag is unlock state. Note: If the unlock bag process time exceeds the set **unlock bag process timeout period**, the controller has not detected **I25**(Bag Released) , then the controller will stop output **O21**(Clamper PWM), and alarm for bag loosening timeout.

### 8.2.2 MotorDrive Dual-Limit clamper bag

Ordinary motor double limit control clamping /releasing bag: The IO quantity involved is: **O6**(Lock Bag) / **O27**(Bag Unlock), **I21**(Bag Locked)/ **I25**(Bag Released). I25 is determined by the type of loose bag DIR signal type.

Take the process of adding a unlock bag in the net weigher mode as an example:

- **Process lock bags:** The instrument output bag clamping signal controls the bag loosening motor to rotate in the direction of bag clamping until the bag clamping in place signal is detected and the output of the bag clamping signal is stopped. At this time, the bag clamping mechanism is in the bag clamping state. Note: If the bagging process time exceeds the set clamper close timeout, the controller has not detected the bag in place signal, then

the controller will stop outputting the bagging signal and the alarm for clamper close timeout.

- **Process unlock bags:** The instrument outputs a loosening signal to control the bag clamping motor to rotate in the direction of loosening the bag until it detects that the loosening signal is in place, and then stops outputting the loosening signal. At this time, the bag clamping mechanism is in a loosening state. Note: If the unlock bag process time exceeds the set clamper open timeout and the controller has not detected the unlock bag in-position signal, the controller will stop outputting the unlock bag signal and the alarm for clamper open timeout.

### 8.2.3 MotorDrive Single-Limit clamper bag

Ordinary motor dual output control control lock unlock bag: the IO quantity involved is: **O6**(Lock Bag) / **O27**(Bag Unlock), **I21**(Bag Locked).

Take the process of adding a unlock bag in the net weigher mode as an example:

- **Process lock bags:** the controller controls the IO output signal, and the output signal until the detection of the bag locked signal input is valid, the output signal output is invalid, and the device pocket is realized.

- **Process unlock bags:** the controller controls the IO output signal to realize the unlock bag of the device, and the output signal duration is the unlock bag output, and the output signal output is invalid. Note: If the bagging process time exceeds the set clamper close timeout, the controller has not detected the bag locked signal, then the controller will stop outputting the bagging signal and the alarm for clamper close timeout.

## 8.3 Motor discharge part

### 8.3.1 Stepper motor discharge

Stepper motor control discharge: The IO quantity involved is: **O23**(DISC Gate PWM) **O24**(DISC DIR), **I22**(DISC Gate Opened Pos.).

Take the discharging as an example:

- **Discharge opening process:** controller control **O24**(DISC DIR) output, to ensure that the motor rotation direction is the door opening direction, and then **O23**(DISC Gate PWM) according to the set **DISC motor open frequency** to output pulses, control the discharge stepper motor to the direction of rotation of the discharge door, stop outputting pulse signals when the number of discharge pulses reaches the set value, and the discharge mechanism is in the open door state.

- **Discharge closing process:** After the discharge door is opened, if the weight of the controller detection hopper is lower than the **near zero value**, the DISC delay timer will be started. After the discharge delay time is over, the controller change **O24**(DISC DIR) output is closed. **O23**(DISC Gate PWM) output according to the set **DISC motor close frequency** to output the pulse, control the discharge stepper motor to rotate in the



closing direction, until the detection **I22**(DISC Gate Opened Pos.) input is valid, stop output pulse signal, and the discharge mechanism is in the close door state.

Note: If the door closing process time exceeds the set DISC gate close timeout , the controller has not detected the door closing in-position signal **I22**(DISC Gate Opened Pos.) , then the controller will stop output **O23**(DISC Gate PWM) , and the alarm for DISC gate close timeout .

### 8.3.2 MotorDrive single-limit discharge

Ordinary motor forward and reverse single limit mode to control unloading: the IO quantity involved is: **O28**(DISC Gate Close), **I24**(DISC Gate Closed Pos.).

Take the unloading process as an example:

- **Discharge opening process:** At the beginning of the unloading process, the controller output discharge signal controls the unloading motor to rotate in the direction of the discharge opening, and continuously DISC gate open timer effective time set, and then closes the unloading signal Output.

- **Closing the discharge process:** After the discharge door is opened, the controller near the hopper weight is less than near zero value, then the discharge start delay time, after the discharging delay time ends, the discharge door closing output signal, to control the discharge motor closing the discharge direction of rotation until the signal input for the discharge door being fully closed is detected, at which point the discharge door is in a closed state. **Note:** If the discharge door closing process time exceeds the set DISC gate close timeout, the controller has not detected the discharge door closing in-position signal, then the controller will stop output and the alarm **discharge closes the timeout** .

### 8.3.3 MotorDrive dual-limit discharge

Ordinary motor forward and reverse double limit mode control discharge: the IO quantity involved is: **O9**(DISC), **O28**(DISC Gate Close), **I24**(DISC Gate Closed Pos.), **I22**(DISC Gate Opened Pos.) Take the unloading process as an example:

- **Discharge opening process:** At the beginning of the unloading process, the instrument outputs the unloading signal to control the unloading motor to rotate in the direction of the unloading door opening until the signal input for the unloading door opening is valid, and then stops outputting the unloading signal. At this time, the unloading door is in the open state. Note: If the discharge door opening process time exceeds the set **DISC gate close timeout**, the controller has not detected the discharge door open door in-position signal, then the controller will stop output, and the alarm for DISC gate open timeout.

- **Discharge closing process:** After the discharge door is opened, if the weight of the controller detection hopper is lower than the **near zero value**, then the discharge start delay time, after the discharging delay time ends, the discharge door closing

output signal, to control the discharge motor closing the discharge direction of rotation until the signal input for the discharge door being fully closed is detected, at which point the discharge door is in a closed state. Note: If the discharge door closing process time exceeds the set DISC gate close timeout, the controller has not detected the discharge door closing in-position signal, then the controller will stop output and the alarm for DISC gate close timeout.

#### 8.3.4 Normal motor rotating discharge

Ordinary motor one-way rotation one-way single limit mode control discharge: the IO quantity involved is: **O9(DISC)**, **I24(DISC Gate Closed Pos.)**.

Take the unloading process as an example:

● **Discharge opening process:** At the beginning of the unloading process, the controller output discharge signal controls the unloading motor to rotate in the direction of the discharge opening, and continuously DISC gate open timer effective time set, and then closes the unloading signal Output.

● **Discharging and closing process:** After the discharge door is opened, if the weight of the controller detection hopper is lower than the **near zero value**, then the discharge start delay time, after the discharging delay time ends, the discharge door closing output signal, to control the discharge motor closing the discharge direction of rotation until the signal input for the discharge door being fully closed is detected, at which point the discharge door is in a closed.

**Note:** If the discharge door closing process time exceeds the **discharge closing timeout time**, the controller has not detected the discharge door closing in-position signal, then the controller will stop output and the alarm **discharge closes the timeout**.

#### 8.3.5 Motor debug function

Motor debug function is for the convenience of users quickly determine the door size of coarse, medium, fine flow. Take door size of debug fine flow for example as below.

Steps as below:

- Step 1: The left side of the interface is the current coarse, medium, fine pulse count. You can modify the data in fine flow pulse input box.
- Step 2: Click "Manual Fi-Fill" button, then controller output fine filling signal. User can determine whether the current pulse is appropriate by checking the opening size of the charging door. (Note: click "Manual Fi-Fill" again to close fine flow. Controller can only be in a state, can not be in the state of coarse flow or medium flow at the same time),
- Step 3: If the pulse number has been modified, press the "save" button to save the modified pulse number. If do not want to save the modified pulse number, exit the motor debugging interface to restore the previous coarse, medium, fine pulse number.

## 8.4 Tractor working process

Stepper motor control tractor: The IO quantity involved is: **O61**(Slider PWM)/**O62**(Slider DIR) /**O63**(Clamping Arm PWM) /**O64**(Clamping Arm DIR) /**O65**(Bracing Bags Output) /**I52**(Slider Backward Locked)/ **I53**(Clamping Arm Bag Released)

The tractor is used in net weigher and gross weigher mode:

### ●Slider

**Reset:** Power on and return to the origin at power-ON go 0 Pos. Freq. Check if the I52 (Slider Backward Locked) signal is in place. If the signal is not detected within slider backward timeout, an alarm will be output.

**Slider Forward:** After I52 is effective, detect the control signal (internal signal) of the traction machine. After slider forward predelay removing the slider, start the motor (starting frequency starts, O61 output is effective), and reach the moving frequency after acceleration time. Determine the start of deceleration (internal calculation judgment), complete the number of running pulses after deceleration time (O61 is invalid).

**Slider Backward:** Wait for the signal to loosen the bag, start the motor after slider backward predelay time before moving back (starting frequency starts, O61 output is valid), and reach the moving frequency after acceleration time. Determine the start of deceleration (internal calculation judgment), complete the number of running pulses after deceleration time (O61 is invalid). If the slider moves back to the limit point at the starting frequency and is not detected within the timeout period, an alarm will be triggered.

### ● Clamping Arm

**Reset:** Power on and return to the origin at power-ON go 0 Pos. Freq. Check if the I53 (Clamping Arm Bag Released) signal is in place. If the signal is not detected after the clamp arm loose bag timeout, an alarm will be output.

**Bag clamping:** After detecting the control signal (internal signal) of the clamping arm, the motor is started after clamping arm lock predelay time (starting frequency starts, O63 output is effective), and the acceleration time reaches the clamping arm frequency. Determine the start of deceleration (internal calculation judgment), complete the number of running pulses after deceleration time (O63 is invalid).

**Unclamping bag:** After the bag holding time is completed, start the motor (starting frequency starts, O63 output is effective), and reach the loose bag frequency after acceleration time. Determine the start of deceleration (internal calculation judgment), complete the number of running pulses after deceleration time (O63 is invalid).

## 9. Peripheral working process

### 9.1 Patting bag

IO function involved in: Output switch quantity-“O11(Patting Bag)”.

To use the bag patting function, first set the bag patting function in the bag patting parameters under the peripheral parameters. Different scale structures correspond to different optional bag patting modes.

The bag-making function consists of three optional processes: “When Hold”, “When Filling”, “All Time”.

#### **When Hold**

If you want to use when hold after patting bag function, After the fixed value is completed, the bag will be directly patted after the fixed value is reached. The output of " Patting ON Timer " and " Patting OFF Timer " will be considered as one bag beating. After reaching the "bag beating times after the fixed value", the bag beating output will be stopped after the fixed value is reached.

#### **When Filling:**

If the bag patting during filling is set, if the current weight is greater than the start-up weight 1 during the filling process, the bag patting during filling will be activated, and the " Patting ON Timer " and " Patting OFF Timer " will be output once each, which is considered as one bag patting. After reaching the "Patting Times(Filling) 1", the bag patting output during feeding will be stopped. During the feeding process, the starting weight of the bag is provided three times, corresponding to the number of bag samplings. The starting weight of start-up weight 1, start-up weight 2, start-up weight 3, and the corresponding number of bag patting times can be set according to the on-site situation. (Note: If the feeding enters the fine filling process, the bagging process will be forcibly terminated.)

#### **All Time:**

If bag patting is performed after setting the constant value during filling, bag patting should be performed during the feeding process and after the constant value is set. The bag patting parameters should be set based on the bag patting when hold and bag patting when filling.

#### **Extra patting bag:**

After all the bags are output, an additional bag output is performed. The effective time is the extra patting timer, and the invalid time is the patting off timer. End the extra shot output after the bag is taken once.

### 9.2 Coding

IO function involved in the coding function is: "O43(Coding)".

After the clamper bag is completed, if the code device is turned on and the “coding timer” is not 0, the “code start delay timer” will be started. After the delay is over, the code delay will be started. The time is “coding timer ”, after the time is up, the coding process ends.

(Note: If " Disable Fill/Discharge When Coding " is turned on, the loading and unloading function is prohibited during the code process).

### 9.3 Conveyor

IO function involved in the conveyor function is: "**O42(Conveyor1)**".

After the filling value is over, check whether the "conveyor Control" is set to level 1 conveyor/level 2 conveyor/level 3 conveyor, if in non closed mode, run the "Conveyor1 Start Delay Timer", After the delay time, the conveyor starts to run, and the "Conveyor1 Running Timer" is counted. Stop running.

Under the net weigher scale structure, if the previous scale conveyor is still running, stop the conveyor before unloading.

Under the gross weigher scale structure, if the conveyor of the previous scale is still running, stop the conveyor before the unlock bag.

### 9.4 Printing

After connecting the printer, you need to set the communication parameters of the controller and select the communication protocol as the printing method. The print format is available in 24 columns and 32 columns. The printing language is available in both English and Chinese, and the number of lines to be printed can be set.

### 9.5 Sewing machine

IO function involved in the sewing machine function is: "**O44(Sewing)**", "**O45(String Cut)**", "**I26(Sewing Start)**", "**I27(Sewing E-Stop)**".

Method 1 (Sewing ON Timer is not 0): When the **I26(Sewing Start)** (pulse) input signal is valid, the sewing machine operation process begins. First, there is a sewing start delay timer, and after the delay time is reached, it is assumed that the sewing machine has started in place. Then, the sewing machine output begins. When the sewing machine output is valid for the sewing ON timer, the sewing machine stop delay timer begins, and at the same time, the cutter predelay time begins. When the sewing machine stop delay timer is over, the sewing machine output becomes invalid, and when the cutter predelay timer is reached, the cutter begins to work. The working time is the string cut on timer. When the string cut on timer is over, the cutter stops working. The process is complete.

Method 2 (Sewing ON Timer is 0): After the **I26(Sewing Start)** (level) input signal of the sewing machine is valid, the sewing machine starts with sewing start delay timer. After the delay time is up, the sewing machine starts again to check whether the input signal is valid. If it is invalid, the sewing machine does not output the signal. After the delay time is up, the sewing machine starts working. The continuous output time is the output time of the sewing on timer. After the sewing on timer of the sewing machine arrives, there is a sewing stop delay timer before starting the sewing machine to stop, and at the same time, there is a cutter predelay timer for starting the cutting machine. The sewing machine continues to work and output, with a duration of the sewing machine shutdown delay time. When the cutter predelay timer for starting the cutter machine reaches, the cutter machine starts

working, and the working time is the string cut on timer of the cutter machine. After the output time of the cutter machine reaches, the cutter machine stops working.

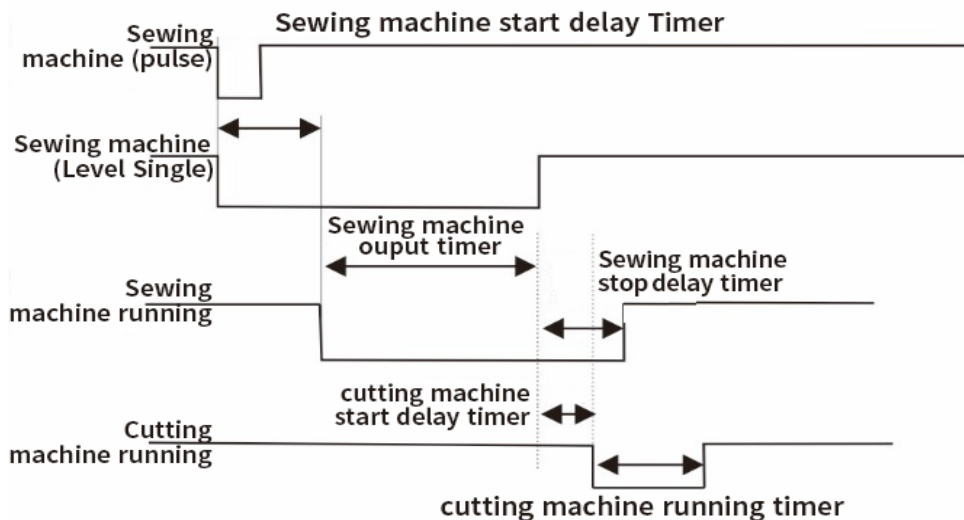

## 9.6 Discharge Shaking

Discharge shaking function involved I/O modules are: **O50(DISC Shaking)**  
**【Individual Shaking】**

When the discharge shaking is set to " Individual Shaking ", if the current discharging time is longer than the set of DISC shaking trigger time, began to discharge shaking output, according to DISC shaking on timer and DISC shaking off timer combination for a discharge time shaking, when DISC shaking times reaches the set of discharge after the DISC shaking times, discharge end of the vibrating process and output alarm stop.

### **【DISC Shaking】**

At the effective unloading time, the switch quantity DISC Shaking output is valid. After the DISC shaking trigger time ends, the DISC shaking logic function is executed, and a combination of one DISC shaking on timer and one DISC shaking off timer is used to form one DISC shaking. When DISC shaking times reaches the set DISC shaking times, the DISC shaking process ends and an alarm is output to stop the machine.

## 9.7 Fill&DISC Overtime Parameter

If “Fill& DISC OverTime Switch” turns on,in running state, in the process of coarse, medium and fine filling and discharging, if the current process delay is longer than the Co-fill, Me-fill, Fi-fill overtime and discharging overtime, the output timeout alarm and stop.

## 9.8 Auxiliary Pulse

Auxiliary Pulse function involved I/O module are: “**O46~O49**(Aux. Pulse1 Ctrl~ Aux. Pulse 4 Ctrl)”, “**I28~I31**(Aux. Pulse1 Ctrl~ Aux. Pulse4 Ctrl)”.

Take Auxiliary Pulse 1 for example:

### **Pulse mode:**

In controller stopped or running state, when the I/O Module input "**I28**(Aux. Pulse1 Ctrl )" effectively, the switch output **O46**(Aux. Pulse1 Ctrl) to start the output, continuous

output Settings " Aux. Pulse 1 ON Time ", after time to stop output, waiting for the set of " Aux. Pulse 1 OFF Time " to the later, once again began to output. Stop output until the " Aux. Pulse 1 Execute Time " reaches, and turn off the auxiliary pulse switch.

If the " Aux. Pulse 1 Execute Time " is set to 0, the output process will continue in a loop.

During the execution of the auxiliary pulse, if the switch input **I28**(Aux. Pulse1 Ctrl) is valid, the output of **O46**(Aux. Pulse1 Ctrl) will stop.

**Level mode:**

1. Set parameters and I/O Module: Click the parameter of "Aux. pulse Control" in "Peripherals" parameters - "Aux. Pulse Ctrl", select the type of "Always ON" for the corresponding pulse control, set the " Aux. Pulse 1~4 ON Time " of the corresponding pulse as 2 seconds, and set the " Aux. Pulse 1~4 OFF Time " of the corresponding pulse as 2 seconds. Select the input port and output port of the auxiliary pulse in the "IO Function " parameter.

2. Perform operation: select "Always ON", continue to give high level at the input end set, and start the Aux. Pulse 1~4 ON Time at the same time, and continue to be effective until the effective time of Aux. Pulse 1~4 ON Time ends at 2s. At this point, the output of the trigger signal becomes invalid until the Aux. Pulse 1~4 OFF Time ends at 2s. When the Aux. Pulse 1~4 OFF Time ends, the output end becomes effective again, and the effective time of auxiliary pulse is restarted, so as to cycle. Until the input terminal no longer input high level, the output signal port no longer output high and low level.

## 10. Dimension (mm)

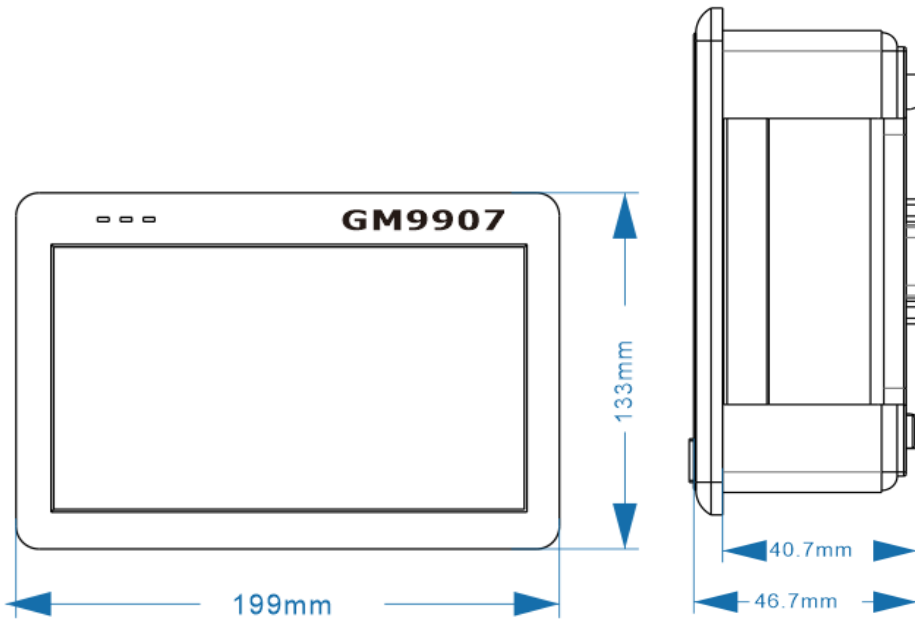

Mounting hole size

