

GMT-X4

DIN Rail Mount Four-Channel Weighing Transmitter



GMT-X4 is a DIN rail mounted weighing transmitter with four-channel. It has the characteristics of compact design, stable performance, and easy operation, which can be used for various weighing applications, such as weight checking, loss-in-weight, liquid filling, batching, vessel and silo weighing, etc.



HARDWARE HIGHLIGHT



- Stainless steel housing with compact design(62X134X128mm);
- Different configuration choices, a variety of combination;

Standard

- ① 4-channel of 6-wire load cell interfaces;
- ② RS485 & RS232;
- ③ 4 Input 8 Output I/O;

Option1

Modbus TCP /IP or EtherNet/IP or ProfiNet or EtherCat or CCLink IE;

Option2

4-channel analog output;

Option3

CAN communication;

(Option1, 2, 3 can be selected at the same time.)



SOFTWARE HIGHLIGHT

- Zero point reset function: support resetting the zero point as before power failure when re-powering;
- Theoretical value calibration, stable within 3s of the calibration process automatically;
- Remote monitoring and configuration by PC with Modbus TCP connecting up to 6 devices at once;
- Input anti-vibration function, which time can be set.

Specification

General Specifications	Model	GMT-X4
	Power	DC 24V \pm 5%
	Size	62mm \times 134mm \times 128mm
	Weight	Approx. 880g
	Operating Environment	-10 \sim 40°C; 90%R.H,No Condensation
	Storing Environment	-40 \sim 60°C; 90%R.H,No Condensation
	Power Dissipation	10W
Measurement Parameters	Weighing Platform Excitation Voltage	5V, 200mA(MAX)/channel
	Weighing Platform Requirement	4 simulation scale interface, can connect up to 40 load cell with 350 Ω , support sensitivity 1mV/V, 2mV/V, 3mV/V
	Sensitivity	0.1uV/d
	Non-Linearity	0.01% F.S
	A/D Conversion Speed	50/60/100/120/200/240/400/480/800/960/SPS
	Maximum Display Accuracy	1/1,000,000

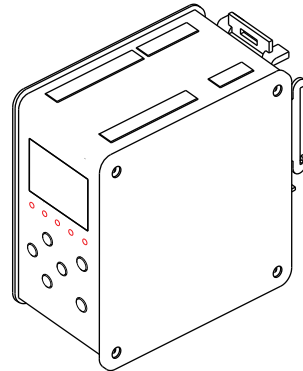
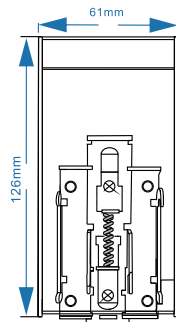
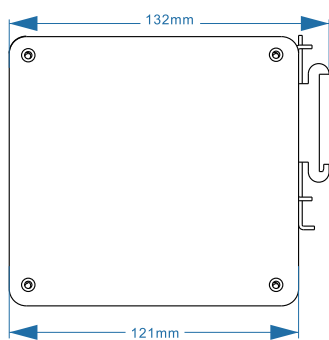

Application Diagram

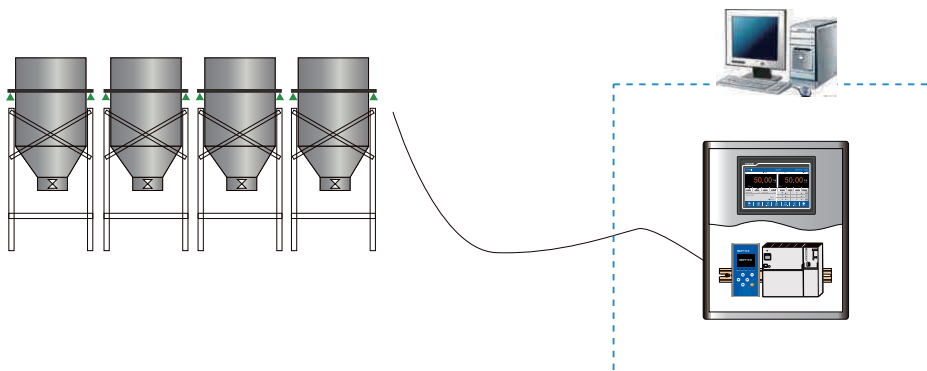

Multi-material batching application