

GMT-X4

Weighing Transmitter (Intelligent Junction box)



GMT-X4 weighing indicator with intelligent junction box built in can easily monitor the defaulted load cell.



FEATURES

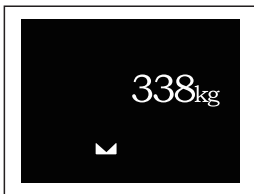

- Main display
- Up to 6 digits

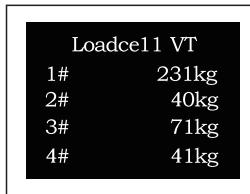

- Weight display
- Individual load cells

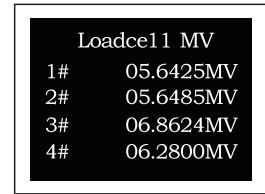

- Millivolt display
- Individual load cells



- Main display
- Error notice
- Load cell failure

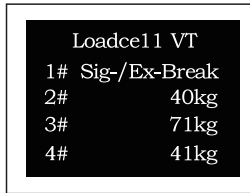

- Weight display
- Error notice
- Defaulted load cell

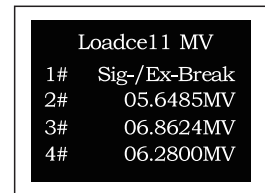

- Millivolt display
- Error notice
- Defaulted load cell



HARDWARE HIGHLIGHT

- Stainless steel housing with compact design(62X134X128mm);

Standard

- ① 4-channel of 6-wire load cell interfaces;
- ② RS485 & RS232;
- ③ 4 Input 8 Output I/O;

Option1

Modbus TCP /IP or EtherNet/IP or ProfiNet or EtherCat or CCLink IE;

Option2

1-channel analog output;

Option3

CAN open;

(Option1, 2, 3 can be selected at the same time.)

CANopen

PROFINET

EtherCAT

Modbus TCP/IP

EtherNet/IP

CC-Link IE

Specification

General Specifications	Model	GMT-X4
	Power	DC 24V \pm 5%
	Size	62mm \times 134mm \times 128mm
	Weight	Approx. 880g
	Operating Environment	-10 \sim 40°C; 90%R.H, No Condensation
	Storing Environment	-40 \sim 60°C; 90%R.H, No Condensation
	Power Dissipation	10W
Measurement Parameters	Weighing Platform Excitation Voltage	5V, 200mA(MAX)/channel
	Weighing Platform Requirement	4 simulation scale interface, can connect up to 40 load cell with 350 Ω , support sensitivity 1mV/V, 2mV/V, 3mV/V
	Sensitivity	0.1uV/d
	Non-Linearity	0.01% F.S
	A/D Conversion Speed	50/60/100/120/200/240/400/480/800/960/SPS
	Maximum Display Accuracy	1/1,000,000

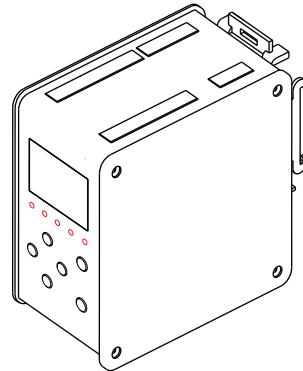
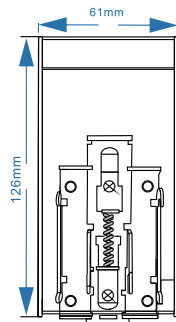
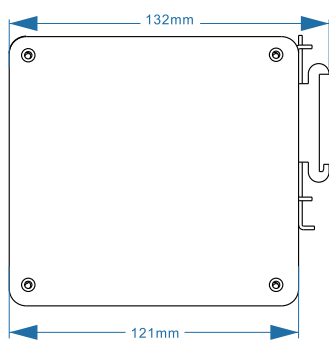

Application Diagram

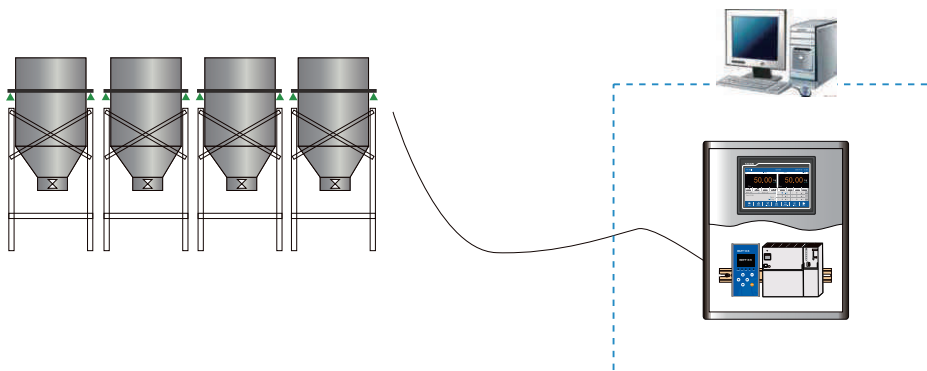

Multi-material batching application